



Serie WH45



TECHNICAL MANUAL
ENGLISH
PATENTED FIRE DAMPER
CIRCULAR SERIES WH45 - 500 Pa.
CERT N° 1812-CPR-1007
INSTALLATION TYPE WITH RESISTANCE CLASS



☎ +34913235805

✉ info@difair.es

🌐 www.difair.es

This is a 42 page manual.



1. Overview	p. 4
1.1. Description	p. 4
1.2. General characteristics	p. 4
1.3. European Standards applied	p. 4
1.4. Certifications and approvals	p. 4
1.5. Components	p. 4
1.6. Available dimensions	p. 4
1.7. Performances	p. 5
1.8. Fire resistance classification according to EN 13501-3-2009	p. 5
1.9. Mechanism type	p. 7
2. Technical data	p. 10
2.1. Dimension	p. 10
2.2. Weights	p. 11
3. Installation	p. 12
3.1. Intended use	p. 12
3.2. Not allowed uses	p. 12
3.3. Positioning brackets before fixing (If required)	p. 12
3.4. Blade rotation axis positioning	p. 12
3.5. Installation of flexible connectors in order to balance out the ventilation ducts expansion	p. 12
3.6. Transfer Application (application not connected to air ducts on one or both sides)	p. 14
3.7. Minimum distances	p. 16
3.8. Construction supports characteristics (special firewall)	p. 17
3.9. Installations within vertical rigid wall	p. 19
3.10. Installation within vertical light wall (plasterboard)	p. 21
3.11. Installation within vertical light wall (gypsum blocks wall)	p. 22
3.12. Installations within floor	p. 23
4. Electrical connections	p. 24
4.1. Electrical wiring	p. 24
4.2. Electrical specifications	p. 26
5. Maintenance and inspections	p. 28
5.1. Periodic inspection and cleaning	p. 28
5.2. Repair	p. 28
5.3. Disposal	p. 28
6. Selection	p. 29
6.1. Air flow rates in relation to the diameter	p. 29
6.2. Air flow rates as a function of the pressure drop	p. 29
6.3. Air flow rates as a function of generated sound levels	p. 29
6.4. Pressure drop and sound level graph Ø 200-560	p. 30
6.5. Pressure drop and sound level graph Ø 450-800	p. 31
6.6. Sound spectrum table	p. 31
7. Accessories and spare parts	p. 32
8. How to order	p. 35
8.1. Motorized fire dampers	p. 35
8.2. Fire damper with manual control	p. 35
8.3. Electric motor driven actuators	p. 36
9. Specification Text	p. 37
9.1. Series WH45 circular fire damper	p. 37
10. Revision Index	p. 38

1. OVERVIEW

1.1. Description

Fire dampers WH45 are devices for use in heating, ventilation and air-conditioning (HVAC) systems at fire boundaries to maintain compartmentation and protect means of escape in case of fire. They satisfy integrity, insulation and smoke leakage criteria for the declared time of fire resistance.

Tested and classified in accordance with EN 1366-2 and EN 13501-3 standards with 500 Pa depression.

Studied and optimized for medium and big diameter ducts focusing on aerulic and acoustical performance.

1.3. European Standards applied

CE certification	EN 15650
Test	EN 1366-2
Classification	EN 13501-3
Thermal fuse reliability	ISO 10294-4
Air tightness	EN 1751
Resistance to corrosive environments	EN 60068-2-52

1.4. Certifications and approvals

CE Certificate of Constancy of Performance	n° 1812-CPR-1007	Efectis
NF certification *Refer to specification Notice Technique NF*	n° 28/02	AFNOR
VKF-AEAI Approval (Switzerland)	n° 23221	VKF-AEAI
RISE Approval (Sweden)	n° SC0190-16	RISE

1.5. Components

1. Casing made from galvanized carbon steel.
2. Mineral fiber gasket between the 2 fire damper casings.
3. Intumescent graphite gasket on inside of casing for the hot seal of the blade once closed
4. Damper blade made from refracting material
5. Gasket to prevent air losses on the mechanism plate.
6. Blade rotation axis, pivots housing.
7. Blade drive with crank and slotted link mechanism
8. Protection box
9. Manual closing device (Test button)
10. Temperature controlled closing device (thermal fuse)

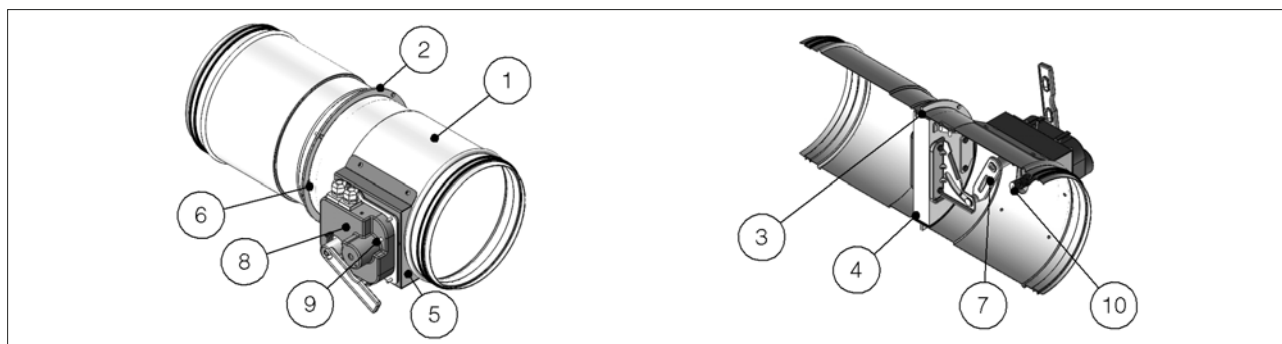

1.6. Available dimensions

∅	mm	200	250	300	315	355	400	450	500	560	600	630	710	800
---	----	-----	-----	-----	-----	-----	-----	-----	-----	-----	-----	-----	-----	-----

1.7. Performances

Performance	Reference standard	Class
Thermal fuse testing	ISO 10294-4	Compliant
Open and Close cycle reliability	EN 15650	Compliant
Resistance to corrosion in humid and saline environments	EN 60068-2-52	Degree of severity 2
Casing tightness	EN 1751	Class C (1)
Blade seal	EN 1751	Class 2 minimum

- (1) Casing leakage class C for diameter bigger than 315 mm as per EN 1751.
Casing leakage class B minimum for diameter less than or equal to 315 mm as per EN 1751 (class C on request).

1.8. Fire resistance classification according to EN 13501-3-2009

Rigid wall						
		EI 180 S (500 Pa)	EI 120 S (500 Pa)	EI 90 S (500 Pa)	EI 60 S (500 Pa)	EI 30 S (500 Pa)
EI 120 S Installation within vertical rigid wall p. 19						
Wall minimum thickness 100 mm			∅	∅	∅	∅
Wall minimum density 500 kg/m ³	W	-	min 200	min 200	min 200	min 200
Mortar or plaster putty sealing ve (i↔o)			max 800	max 800	max 800	max 800
EI 90 S Installation within vertical rigid wall p. 19						
Wall minimum thickness 100 mm				∅	∅	∅
Wall minimum density 500 kg/m ³	D	-	-	min 200	min 200	min 200
Plasterboard and rock wool 100 kg/m ³ sealing ve (i↔o)				max 800	max 800	max 800
Flexible wall						
		EI 180 S (500 Pa)	EI 120 S (500 Pa)	EI 90 S (500 Pa)	EI 60 S (500 Pa)	EI 30 S (500 Pa)
EI 90 S Installation within vertical light wall (plasterboard)						
Wall minimum thickness 100 mm				∅	∅	∅
Wall rock wool density up to 100 kg/m ³ (optional)	D	-	-	min 200	min 200	min 200
Plasterboard and rock wool 100 kg/m ³ sealing ve (i↔o)				max 800	max 800	max 800
EI 120 S Installation within vertical light wall (plasterboard)						
Wall minimum thickness 100 mm				∅	∅	∅
Wall rock wool density up to 100 kg/m ³ (optional)	W	-	min 200	min 200	min 200	min 200
Mortar or plaster putty sealing ve (i↔o)			max 800	max 800	max 800	max 800
EI 90 S Installation within vertical light wall (gypsum blocks wall) p. 22						
Wall minimum thickness 70 mm				∅	∅	∅
Wall minimum density 995 kg/m ³	W	-	-	min 200	min 200	min 200
Plaster putty sealing ve (i↔o)				max 800	max 800	max 800
EI 120 S Installation within vertical light wall (gypsum blocks wall) p. 22						
Wall minimum thickness 100 mm				∅	∅	∅
Wall minimum density 995 kg/m ³	W	-	min 200	min 200	min 200	min 200
Plaster putty sealing ve (i↔o)			max 800	max 800	max 800	max 800
Floor						
		EI 180 S (500 Pa)	EI 120 S (500 Pa)	EI 90 S (500 Pa)	EI 60 S (500 Pa)	EI 30 S (500 Pa)
EI 90 S Installation within floor p. 23						
Floor minimum thickness 100 mm				∅	∅	∅
Floor minimum density 650 kg/m ³	W	-	-	min 200	min 200	min 200
Mortar sealing ho (i↔o)				max 800	max 800	max 800
EI 120 S Installation within floor p. 23						
Floor minimum thickness 150 mm				∅	∅	∅
Floor minimum density 650 kg/m ³	W	-	min 200	min 200	min 200	min 200
Mortar sealing ho (i↔o)			max 800	max 800	max 800	max 800
EI 180 S Installation within floor p. 23						

Floor						
		EI 180 S (500 Pa)	EI 120 S (500 Pa)	EI 90 S (500 Pa)	EI 60 S (500 Pa)	EI 30 S (500 Pa)
Floor minimum thickness 150 mm		Ø	Ø	Ø	Ø	Ø
Floor minimum density 2200 kg/m ³						
Mortar sealing	W	min 200 max 800	min 200 max 800	min 200 max 800	min 200 max 800	min 200 max 800
ho (i↔o)						

Ø is the minimum and maximum nominal diameter of fire dampers in mm

ve Vertical installation

ho Horizontal installation

(i↔o) Origin of fire irrelevant

Pa Pascal of depression

E Integrity

I Thermal insulation

S Smoke seal

W Wet method sealing

D Dry method sealing

Cert. N° 1812-CPR-1007

1.9. Mechanism type

Mechanism type selection must be done according to national legislation and according to building type where fire damper will be installed. In particular it must be considered if fire alarm system or smoke detection system need specific control over the fire damper or if periodic controls (such as opening and closing) are required.

1.9.1. Manual / Manual with magnet

1. Manual opening lever
2. Protection box
3. Lever position when the blade is open
4. Lever position when the blade is closed
5. Magnet knob (for magnetic version)
6. Closed blade indicator
7. Open blade indicator
8. Manual closing button

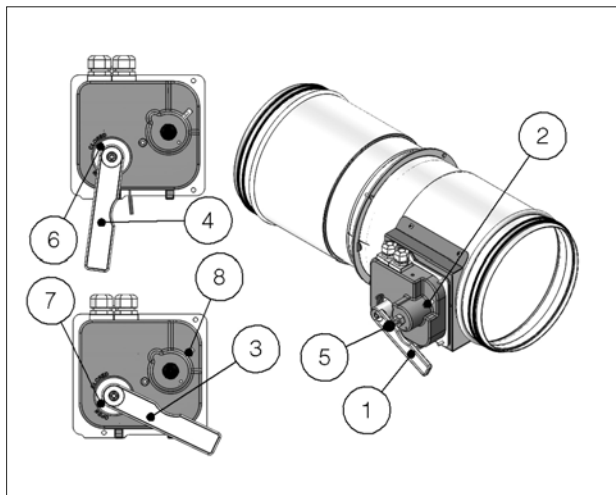

Blade closing mode

Automatic closing with thermal fuse.

The control mechanism has a thermosensitive element that automatically closes the blade when the temperature in the duct exceeds 70°C (or 95°C for the fire damper with 95°C thermal fuse).

It is possible to close the damper by pressing the indicated button.

If the manual mechanism is equipped with electromagnet it is possible to remotely close the fire damper.

The manual command mechanism with magnet is equipped with an electromagnet which, in case power is interrupted (interruption magnet version) or when power is supplied (input magnet version), commands the closing of the damper.

Blade opening mode

Make sure that the damper is open before the ventilation system start-up, otherwise there is a risk of product malfunction.

In case of closed damper by pressing the closing button or remotely by electromagnet (magnetic version), it is possible to manually open the fire damper blade by rotating the lever antyclockwise.

For power supply interruption electromagnet, provide power supply and pull the magnet knob before opening the fire damper.

In case of closed damper as a result of the action of the thermosensitive element, it is possible to manually reopen the damper by rotating the lever counterclockwise once the element has been replaced.

Position indication microswitches

On request, the fire damper can be supplied with position microswitches (SA/SC/S2 optional) that signal the blade position (open or closed). Refer to Electrical connections [p. 24](#) paragraph for more details.

Closing by remote control

With power supply input or interruption magnet (WH45M version only).

Temperature calibration of thermosensitive element for automatic damper closing

70 °C±7 °C (Standard)

95 °C±9 °C (On request).

1.9.2. Belimo motorized version

1. Manual closing switch
2. Manual opening lever
3. Position indicator
4. Blade locking lever

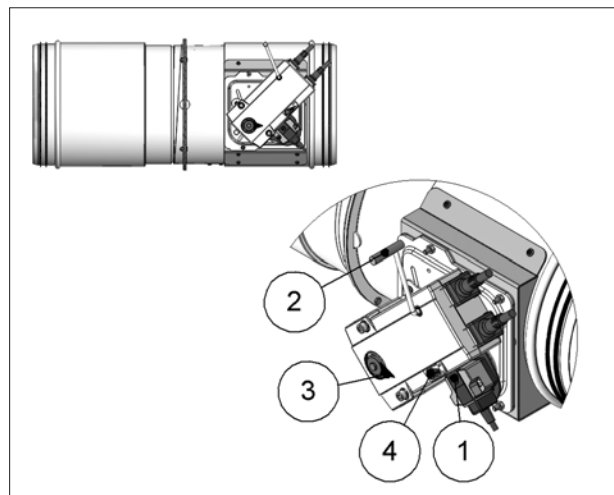

Blade closing mode

Automatic closing with thermal fuse.

The control mechanism has a thermosensitive element that automatically closes the blade when the temperature in the duct or in the room exceeds 72°C (or 95°C for the 95°C version).

To close the damper when the motor is connected, press the switch on the temperature sensor or cut off the power supply.

Blade opening mode

Make sure that the damper is open before the ventilation system start-up, otherwise there is a risk of product malfunction.

To open the damper with the electric motor driven actuator, provide power supply to the motor. Refer to the section Electrical connections [p. 24](#) for further information.

To manually open the damper, use the handle supplied and carefully rotate clockwise to the 90° indicator. To hold the damper in open position operate on the lever indicated in figure.

For VGB/DGB versions to hold the damper in open position, carefully rotate the handle counterclockwise.

During the manual opening of the damper, power must not be supplied to the motor.

Position indication microswitches

The motorized versions are supplied with two microswitches to show the blade's position (open or closed). Refer to the section Electrical connections [p. 24](#) for further information.

Closing by remote control

If power to the motor is cut off, the blade will close.

Temperature calibration of thermosensitive element for automatic damper closing

72 °C±7 °C (Standard)

95 °C±9 °C (On request).

1.9.3. Siemens motorized version

1. Manual closing switch
2. Manual opening lever
3. Screwdriver
4. Position indicator

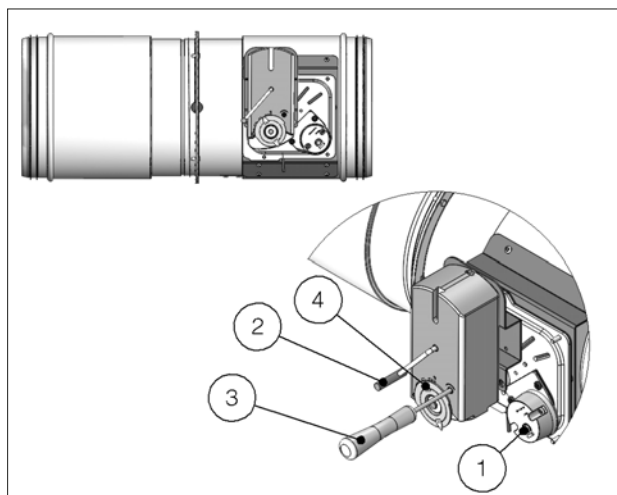

Blade closing mode

Automatic closing with thermal fuse.

The control mechanism has a thermosensitive element that automatically closes the blade when the temperature in the duct or in the room exceeds 72°C (or 95°C for the 95°C version).

To close the damper when the motor is connected, press the switch on the temperature sensor or cut off the power supply.

Blade opening mode

Make sure that the damper is open before the ventilation system start-up, otherwise there is a risk of product malfunction.

To open the damper with the electric motor driven actuator, provide power supply to the motor. Refer to the section Electrical connections [p. 24](#) for further information.

To manually open the damper, use the handle supplied and carefully rotate counterclockwise to the 90 °C indicator. To hold the damper in open position, rotate the screw anticlockwise as shown in the picture.

During the manual opening of the damper, power must not be supplied to the motor.

Position indication microswitches

The motorized versions are supplied with two microswitches to show the blade's position (open or closed). Refer to the section Electrical connections [p. 24](#) for further information.

Closing by remote control

If power to the motor is cut off, the blade will close.

Temperature calibration of thermosensitive element for automatic damper closing

72 °C±7 °C (Standard)

95 °C±9 °C (On request).

1.9.4. Gruner motorized version

1. Manual closing switch
2. Manual opening lever
3. Position indicator

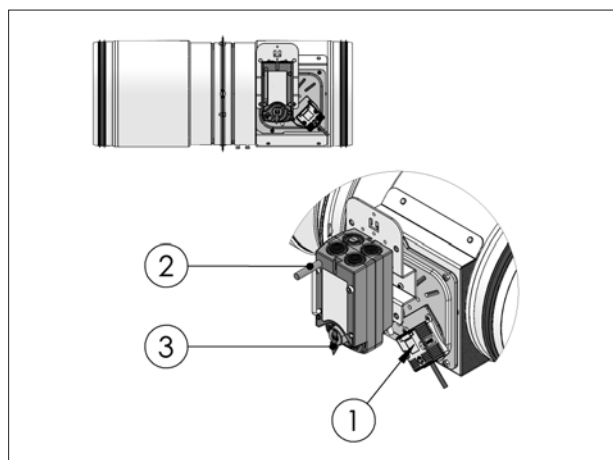

Blade closing mode

Automatic closing with thermal fuse.

The control mechanism has a thermosensitive element that automatically closes the blade when the temperature in the duct or in the room exceeds 72°C (or 95°C for the 95°C version).

To close the damper when the motor is connected, press the switch on the temperature sensor or cut off the power supply.

Blade opening mode

Make sure that the damper is open before the ventilation system start-up, otherwise there is a risk of product malfunction.

To open the damper with the electric motor driven actuator, provide power supply to the motor. Refer to the section [Ref] for further information.

To manually open the damper, use the handle supplied and carefully rotate counterclockwise to the 90 °C indicator. To hold the damper in open position, rotate the screw anticlockwise as shown in the picture.

During the manual opening of the damper, power must not be supplied to the motor.

Position indication microswitches

The motorized versions are supplied with two microswitches to show the blade's position (open or closed). Refer to the section [Ref] for further information.

Closing by remote control

If power to the motor is cut off, the blade will close.

Temperature calibration of thermosensitive element for automatic damper closing

72 °C±7 °C (Standard)

95 °C±9 °C (On request).

2. TECHNICAL DATA

The sizes shown are in mm.

2.1. Dimension

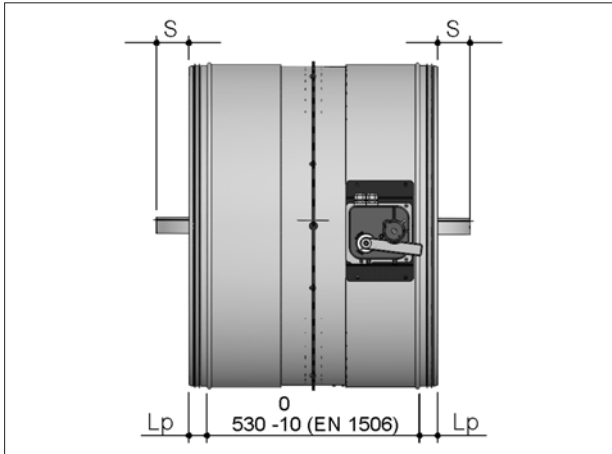

Lp Overlap length between fire damper and duct

Ø	mm	200	250	300	315	355	400
S blade exposition	mm	0	0	0	0	0	0
Lp	mm	45	45	45	45	45	45

Ø	mm	450	500	560	600	630	710	800
S blade exposition	mm	0	0	0	0	0	35	80
Lp	mm	45	45	45	45	45	45	45

2.1.1. Manual

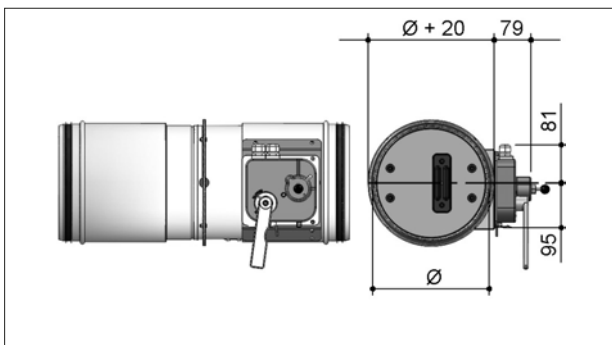

2.1.3. Siemens motorized version

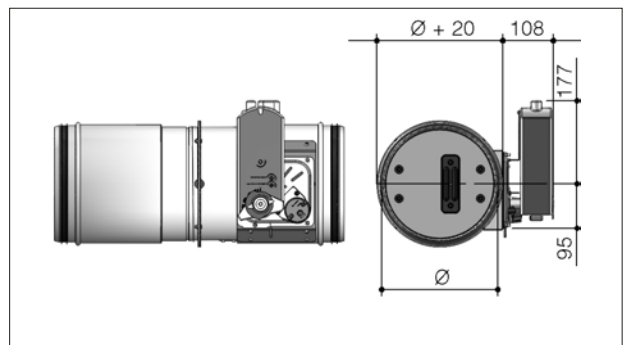

2.1.2. Manual with magnet

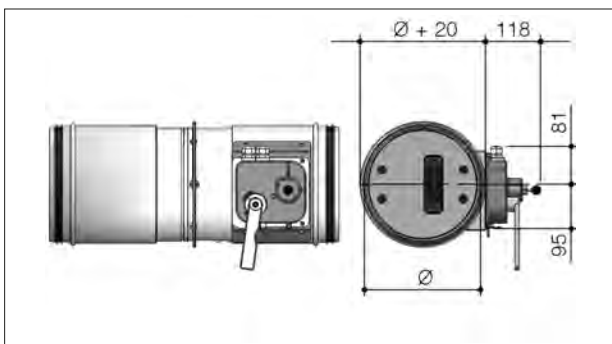

2.1.4. Belimo motorized version

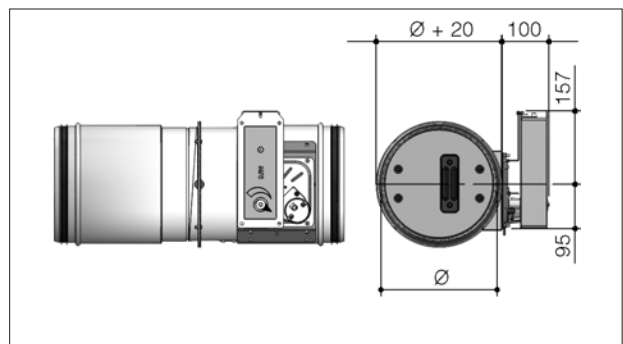

2.1.5. Gruner motorized version

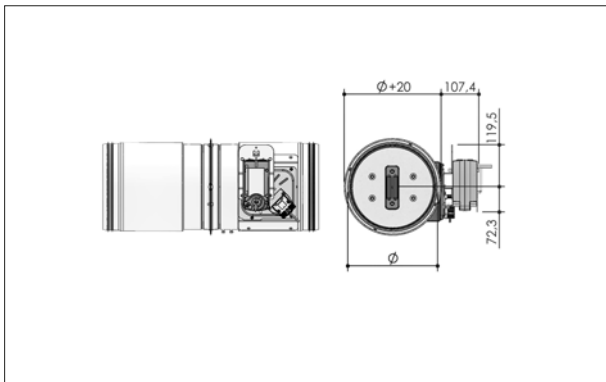

2.2. Weights

\varnothing	mm	200	250	300	315	355	400	450	500	560	600	630	710	800
Weight	kg	7,0	8,0	9,0	10,0	11,0	12,0	14,0	15,0	18,0	20,0	22,0	26,0	31,0

Manual version. Motorized version: +1 kg

3. INSTALLATION

The sizes shown are in mm.

It is recommended to perform a functional test before installation to exclude possible damage during transport and another test immediately after installation to exclude accidental damage to the product and interference with mounting components.

3.1. Intended use

The MP3 fire dampers are "Devices for use in heating, ventilation and air conditioning (HVAC) systems at fire boundaries to maintain compartmentation and protect means of escape in case of fire" according to the 3.1 paragraph of EN 15650:2010 standard.

It is compulsory to install the fire damper according to the instructions indicated in the technical data sheet and manual to maintain the declared performances and, in particular, the fire classes.

The double test (with the mechanism inside and outside the fire area) demonstrated that there is no preferred direction for the position of the damper, both in relation to air flow and the side with the higher probability of exposure to fire, as indicated in standard EN1366-2:2015 (paragraph 6.2).

Use permitted in any civil and industrial building.
Use permitted in saline atmosphere, for example:

- maritime and port environments;
- fish markets;
- slaughterhouses;
- cheese makers.

3.2. Not allowed uses

- Use with installations different to those described in the technical data sheet and manual;
- use as smoke control damper;
- use as shut off damper;
- use in external environments without adequate protection from atmospheric conditions;
- use in explosive environments;
- use on board of ships;
- use in cooker extraction hoods;
- use in pneumatic conveying systems of dust or corn;
- use in ventilation systems within locations subject to chemical contamination;
- use in non inspectable environments;
- installation in fire resistant false ceilings crossings;
- use in ventilation ducts where condensation can occur.

3.3. Positioning brackets before fixing (If required)

1. Positioning brackets

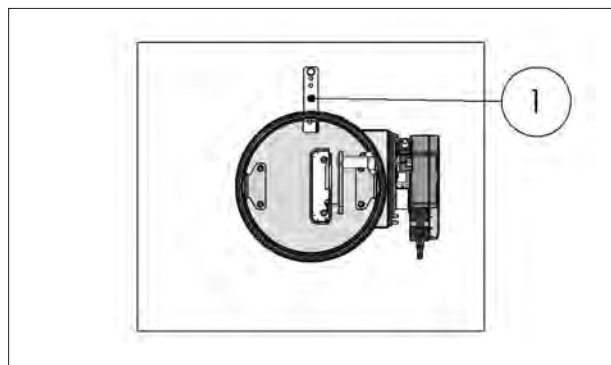

3.4. Blade rotation axis positioning

The fire damper can be installed with the blade axis positioned vertically or horizontally or tilted at any angle.

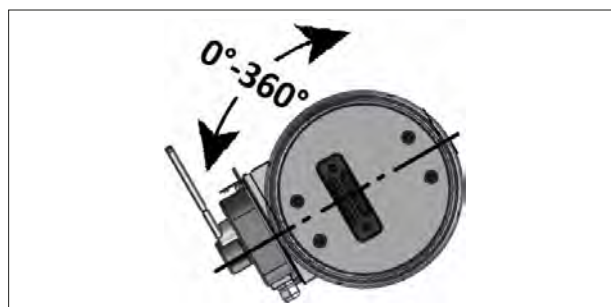

3.5. Installation of flexible connectors in order to balance out the ventilation ducts expansion

ATTENTION: the following indications must be considered binding only if legislation or local regulation where the fire dampers are installed require the use of flexible connectors.

Flexible connectors compensate any duct thermal expansion and wall bending in case of fire.

Flexible connectors are used to limit fire damper stresses due to external forces in case of fire and to preserve fire resistance class.

In general it is always appropriate the use of flexible connectors for the followings installations:

- light walls;
- Plasterboard and rock wool or Fire Batt (Weichschott) sealing;
- Applique fixing system.

Flexible connector must be normal flammability and in case of fire the grounding bonding should disconnect to guarantee the complete separation between fire damper and connected air duct.

When flexible connectors made of conductive material (e.g. aluminum) are used, no additional grounding bonding is required.

Despite flexible connector installation, the fire damper must be installed in the construction support so that its weight does not affect damper's installation position both during normal operation and in case of fire.

It is recommended not to compress flexible connectors in the installation phase.

Flexible connector must be at least 100mm long and in order that possible duct thermal expansions are balanced.

Take care that the flexible connector does not interfere with opening / closing movement of the blade.

Refer to the section Technical data [p. 10](#) for blade exposition values.

3.6. Transfer Application (application not connected to air ducts on one or both sides)

Note: For this application please refer to national legislation to verify if any specific obligation is required.

Following tests performed as per EN 1366-2, section 6.3.6 Standard, it is possible to install the fire damper free from air duct from one or both sides.

- Attention: fire resistance classification for transfer application is conform to section Fire resistance classification according to EN 13501-3-2009 p. 5 limited to EI 90S if the ducted classification is higher.
- End cap with mesh shall be mounted on the side not connected to air duct.
- End cap with mesh is made from galvanized steel sheet.
- End cap with mesh is supplied not installed on the fire damper.
- Refer to the section How to order (transfer Application) p. 15 for codes to use.

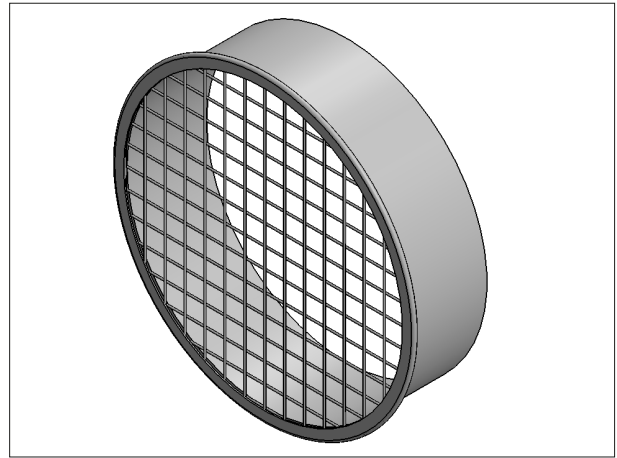

3.6.1. Components (Transfer Application)

1. End cap with mesh (to fix to fire damper with steel screws)

2. Fire damper

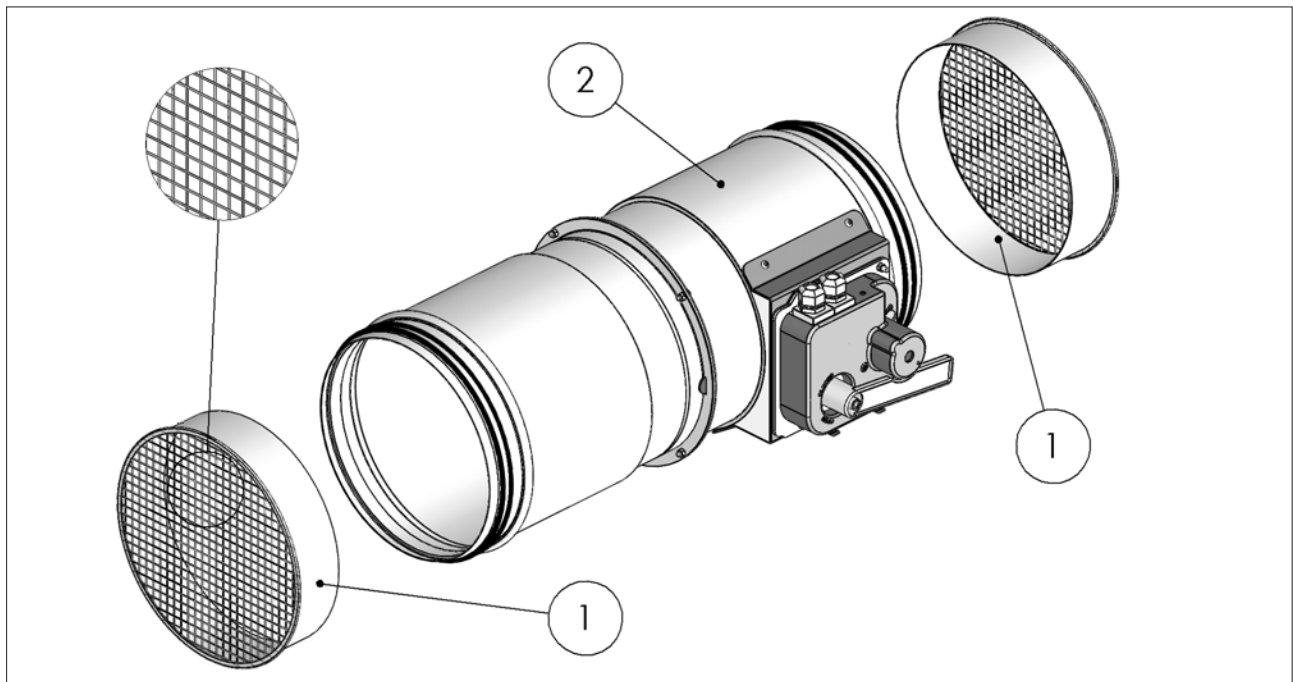

3.6.2. Technical data (Transfer Application)

- | | | | |
|----|-------------------------|----|--|
| 1. | Mechanism side | L1 | End cap length mechanism side |
| 2. | Mechanism opposite side | L2 | End cap length mechanism opposite side |
| 3. | End cap with mesh | Ø | Fire damper nominal diameter |

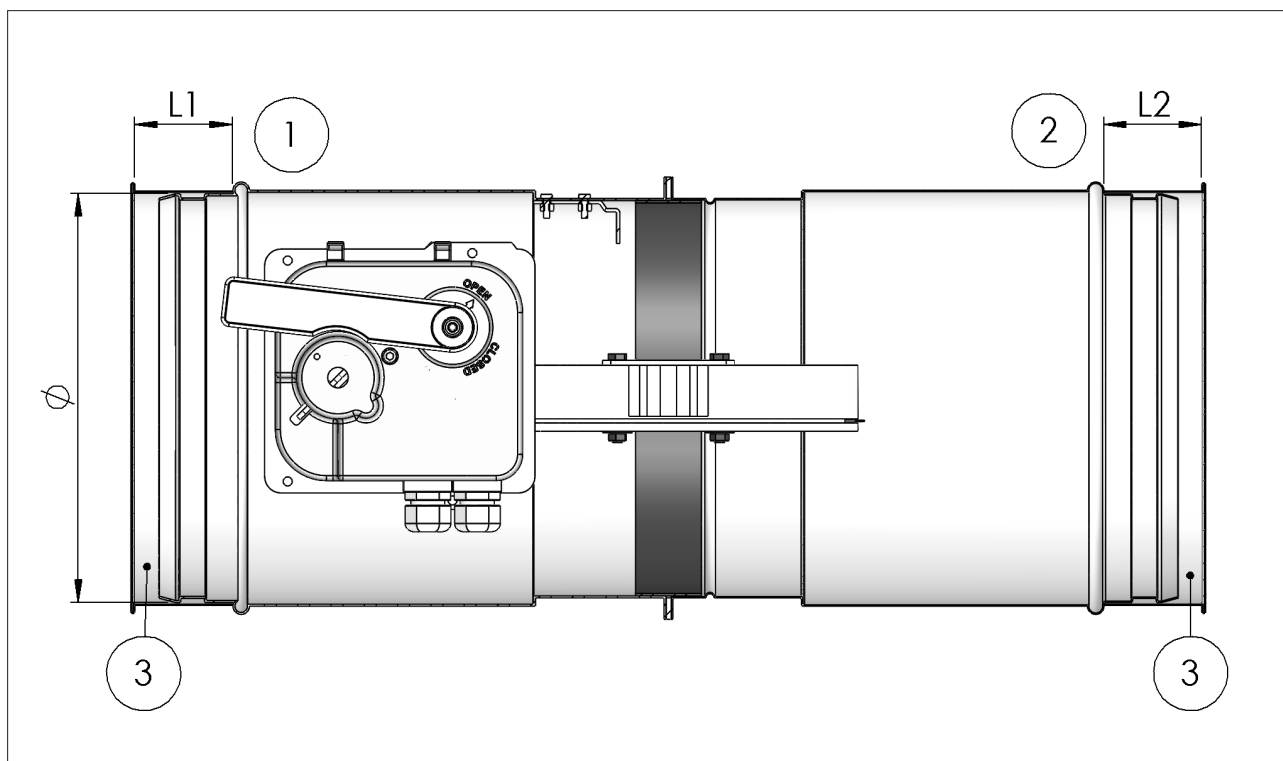

Length of end cap with mesh depending on fire damper diameter Ø.

Ø	L1	L2
200	60	60
250	60	60
300	60	60
315	60	60
355	60	60
400	80	80
450	80	80
500	80	80
560	80	80
600	80	80
630	80	80
710	120	120
800	170	170

- Ø Fire damper nominal diameter
 L1 End cap length mechanism side
 L2 End cap length mechanism opposite side

3.6.3. How to order (transfer Application)

Code		
Type	EPNF	End cap with mesh
Diameter	XYZ	Nominal diameter dimension (mm)
Length	XYZ	Length dimension (mm)

Examples	Code
End cap with mesh length 80 mm for fire damper Ø450 not connected to air ducts on mechanism side	EPNF45080
End cap with mesh length 60 mm for fire damper Ø300 not connected to air ducts on mechanism opposite side	EPNF30060
End caps with mesh length 80 mm (mechanism side) and length 80 mm (mechanism opposite side) for fire damper Ø630 not connected to ducts on both sides	EPNF63080 EPNF63080

3.7. Minimum distances

It is recommended to keep enough space (about 200mm) for using or replacing the control mechanism or for maintenance. Also provide the necessary space to remove the ventilation duct from the damper whenever necessary.

In accordance with Articles 7 and 13 of EN 1366-2 respect the minimum distances indicated below.

Minimum distances

- | | | | |
|----|--|----|--|
| 1. | Side vertical wall | b. | Distance between fire damper and vertical lateral wall / floor |
| 2. | Floor | c. | Distance between fire dampers installed within floor |
| a. | Distance between fire dampers installed within vertical wall | d. | Distance between fire damper and vertical lateral wall |

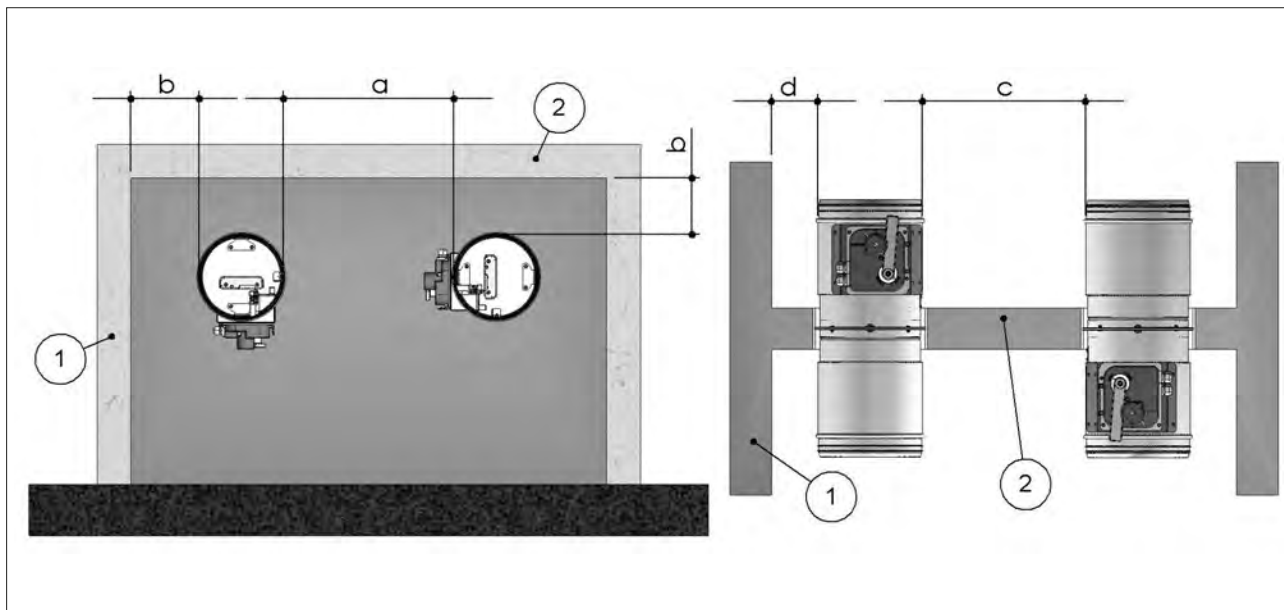

Installation	Fire dampers installed within vertical wall		Fire dampers installed within floor		
	a [mm]	b [mm]	c [mm]	d [mm]	
Rigid wall	EI 90 S Installation within vertical rigid wall p. 19 Plasterboard and rock wool 100 kg/m ³ sealing	50	75	-	-
	EI 120 S Installation within vertical rigid wall p. 19 Mortar or plaster putty sealing	50	75	-	-
Flexible wall	EI 90 S Installation within vertical light wall (plasterboard) Plasterboard and rock wool 100 kg/m ³ sealing	50	75	-	-
	EI 120 S Installation within vertical light wall (plasterboard) Mortar or plaster putty sealing	50	75	-	-
	EI 90 S Installation within vertical light wall (gypsum blocks wall) p. 22 Plaster putty sealing	50	75	-	-
	EI 120 S Installation within vertical light wall (gypsum blocks wall) p. 22 Plaster putty sealing	50	75	-	-
Floor	EI 90 S Installation within floor p. 23 Mortar sealing	-	-	50	75
	EI 120 S Installation within floor p. 23 Mortar sealing	-	-	50	75
	EI 180 S Installation within floor p. 23 Mortar sealing	-	-	50	75

3.8. Construction supports characteristics (special firewall)

The European standard for fire dampers foresees a precise correlation between the wall/floor characteristics and the fire resistance class obtained, as well as the correlation between wall/floor used for the test and wall/floor used for the actual installation.

The test results obtained on a type of wall/floor are valid also for walls/floor of the same type but with greater thickness and/or density than those used in the test.

For plasterboard walls, the test results are also valid for walls with a greater number of plasterboard layers on each side. As a result, the indicated thickness and density characteristics are to be considered as minimum values.

The wall/floor in which the fire dampers are installed must be fire class certified according to the standards foreseen for the structure.

3.8.1. Rigid walls

Can be made with aerated concrete blocks, poured concrete, concrete panels, perforated cell elements in concrete or brick in accordance with the following characteristics:

- minimum thickness 100 mm;
- minimum density 500 kg/m³.

For walls built with perforated elements, it is also recommended that the area of the opening be made from full elements (for example aerated concrete blocks) to guarantee the correct adhesion of the mortar.

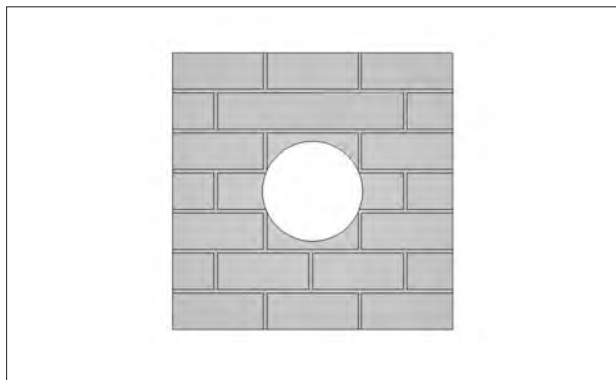

3.8.2. Light plasterboard vertical walls

During testing, light plasterboard walls have been used with the following characteristics:

- U-shaped horizontal metal frame (50 mm) and C-shaped vertical frame (49 mm) made from 0,6 mm thick sheet metal;
- Vertical profiles placed with a maximum spacing of 625 mm between each other;
- Filling made of rock wool with density up to 100 kg/m³ (optional);
- Each side is made from two plasterboard layers 12,5 mm thick, unalined to avoid alignment between the joints of the layer above and below.

The following indications are given for the installation walls:

- metal profiles minimum width: 49 mm;
- metal profiles minimum thickness: 0,6 mm;
- vertical profiles placed with a maximum spacing of 625 mm between each other;

- vertical profile fixing with selfthreading screws or by clinching to the bottom horizontal profile and insertion in the top horizontal profile;
- profiles fixed using self-threading screws or by clinching on every intersection.
- installation of a frame around the damper with base and height where shown in the installation instructions;
- Filling made of rock wool with density up to 100 kg/m³ (optional);
- each side is made from two plasterboard layers 12,5 mm minimum thick, unalined to avoid alignment between the joints of the layer above and below.
- the front plasterboards layers are fixed using long enough screws to pass through the lower plasterboard and attach to the steel profile underneath.

1. Plasterboard thickness 12,5 mm
2. Rock wool density up to 100 kg/m³ (optional)
3. Horizontal U-shaped profile
4. Vertical C-shaped profile
5. Self-drilling screw Ø 3,5 X 25 mm
6. Self-drilling screw Ø 3,5 X 35 mm

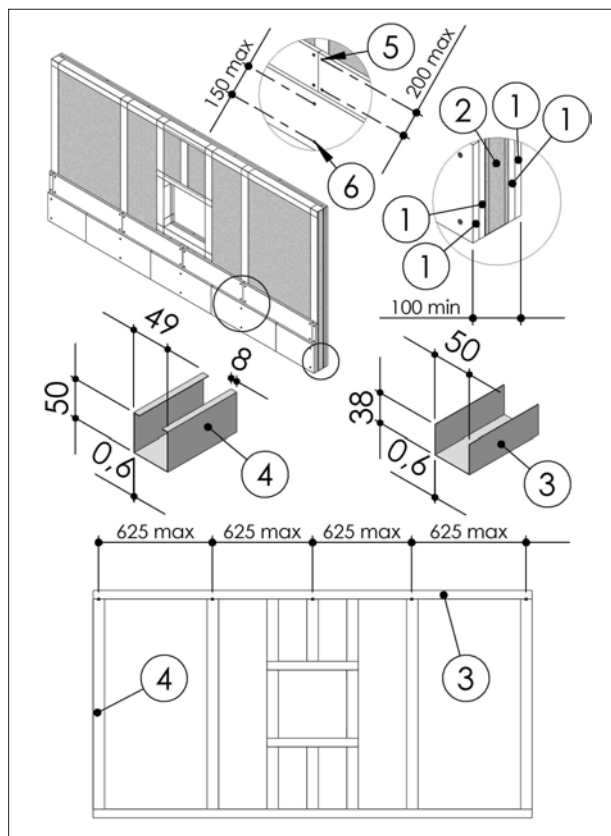

3.8.3. Light plasterboard vertical walls with steel reinforcement

During testing, light plasterboard walls have been used with the following characteristics:

- U-shaped horizontal metal frame (50 mm) and C-shaped vertical frame (49 mm) made from 0,6 mm thick sheet metal;
- Vertical profiles placed with a maximum spacing of 312,5 mm between each other;

- reinforcement sheet;
- Filling made of rock wool with density up to 100 kg/m^3 (optional);
- Each side is made from two plasterboard layers 12,5 mm thick, unalinged to avoid alignment between the joints of the layer above and below.

The following indications are given for the installation walls:

- metal profiles minimum width: 49 mm;
- metal profiles minimum thickness: 0,6 mm;
- vertical profiles placed with a maximum spacing of 312,5mm between each other;
- vertical profile fixing with selfthreading screws or by clinching to the bottom horizontal profile and insertion in the top horizontal profile;
- profiles fixed using self-threading screws or by clinching on every intersection.
- installation of a frame around the damper with base and height where shown in the installation instructions;
- Filling made of rock wool with density up to 100 kg/m^3 (optional);
- each side is made from two plasterboard layers 12,5 mm mininum thick, unalinged to avoid alignment between the joints of the layer above and below.
- the front plasterboards layers are fixed using long enough screws to pass through the lower plasterboard and attach to the steel profile underneath.

1. Plasterboard thickness 12,5 mm
2. Rock wool density up to 100 kg/m^3 (optional)
3. Reinforcement sheet
4. Horizontal U-shaped profile
5. Vertical C-shaped profile
6. Self-drilling screw $\varnothing 3,5 \times 25 \text{ mm}$
7. Self-drilling screw $\varnothing 3,5 \times 35 \text{ mm}$

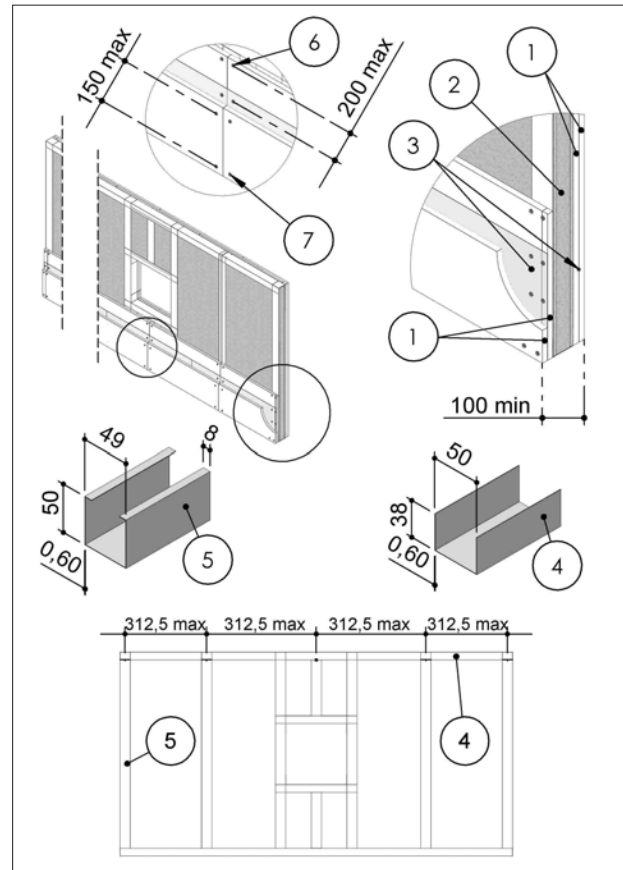

3.8.4. Gypsum blocks light walls

Gypsum blocks wall can be built with special solid gypsum blocks with interlocking shaped edges as indicated in the supplier's instructions and according to the following characteristics:

- minimum thickness 70 or 100 mm according to the type and resistance class required;
- minimum density 995 kg/m³.

It is generally advisable to first build the wall and then provide the opening for the fire damper.

3.8.5. Aerated concrete floors

Aerated concrete floors can be built during installation or with preformed slabs with interlocking shaped edges according to the following characteristics:

- minimum thickness 100 or 150 mm according to the type and resistance class required;
- minimum density 650 kg/m³

3.8.6. Poured concrete floors

Poured concrete floors can be built during installation or with preformed slabs with interlocking shaped edges according to the following characteristics:

- minimum thickness 100 or 150 mm according to the resistance class required;
- minimum density 2200 kg/m³.

3.9. Installations within vertical rigid wall

Refer to the section Construction supports characteristics (special firewall) [p. 17](#) for further information.

Comply with the minimum distances indicated on section Minimum distances [p. 16](#).

Before and after installation please perform a functional test. Refer to section Mechanism type for further information [p. 7](#).

3.9.1. Wall opening

A opening must be provided in the wall as indicated in the table and in the drawing

3.9.2. Damper positioning

Position the damper in the opening so that the side of the closing mechanism extends as indicated in the table and in the drawing.

Close the blade before installing the fire damper.

3.9.3. Filling

Fill the space between the wall and the damper as indicated in the table and in the drawing.

Sealing with concrete is not allowed.

	Fire resistance classification	"D" hole size [mm]	Damper protrusion from the wall "E" [mm]	Wall minimum thickness "S" [mm]	Sealing
EI 90 S Installation within vertical rigid wall					
Wall minimum density 500 kg/m ³	EI 90 S (500 Pa)	Da (Ø + 35) x (Ø + 35) to (B + 50) x (H + 50) (square hole)	215 + Lp	100	Rock wool 100 kg/m ³ with infill plasterboard (thickness 12.5 mm)
EI 120 S Installation within vertical rigid wall					
Wall minimum density 500 kg/m ³	EI 120 S (500 Pa)	From Ø + 25 to Ø + 580 (square or circular hole)	215 + Lp	100	Mortar or plaster putty sealing

EI 90 S Installation within vertical rigid wall

- 1. Rock wool, 100 kg/m³
- 2. Plasterboard arch infill, thickness 12,5 mm
- 3. Self-drilling screw Ø 3,5 X 45 mm
- D Hole size: see table above

- E Damper protrusion from the wall: see table above
- Lp Overlap length between fire damper and duct: see section Dimension p.10

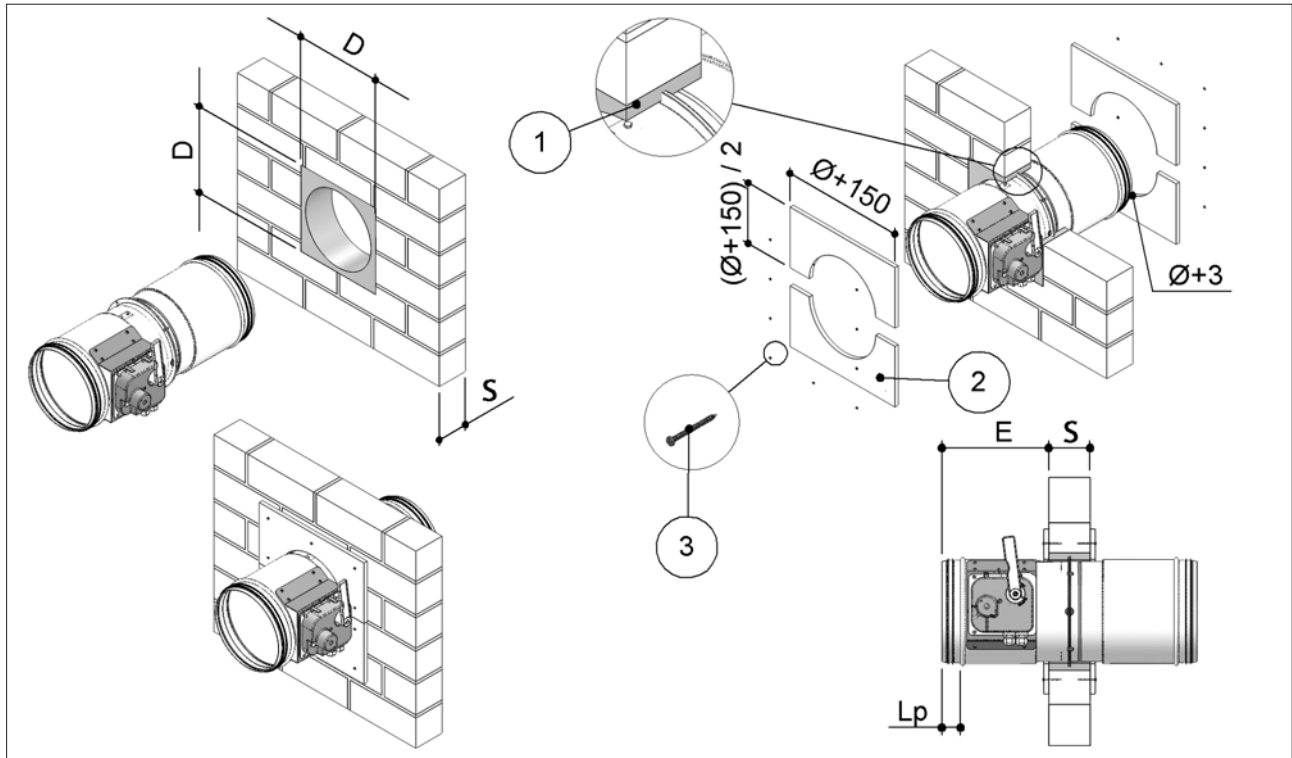

EI 120 S Installation within vertical rigid wall

- 1. Mortar M-10, EN998-2 or plaster putty
- D Hole size: see table above
- S Wall minimum thickness: see table above

- E Damper protrusion from the wall: see table above
- Lp Overlap length between fire damper and duct: see section Dimension p.10

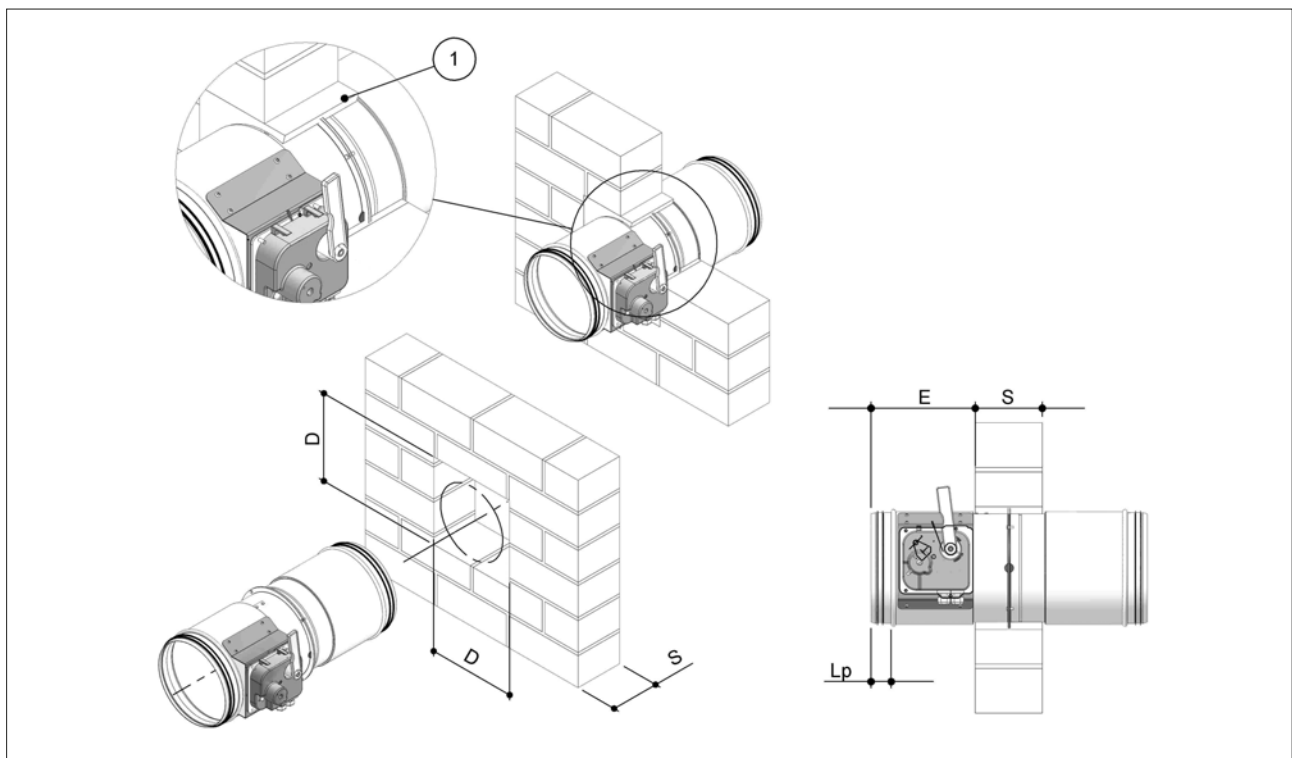

3.10. Installation within vertical light wall (plasterboard)

Refer to the section Construction supports characteristics (special firewall) [p. 17](#) for further information.

Comply with the minimum distances indicated on section Minimum distances [p. 16](#).

Before and after installation please perform a functional test. Refer to section Mechanism type for further information [p. 7](#).

3.10.1. Wall opening

A opening must be provided in the wall as indicated in the table and in the drawing

3.10.2. Damper positioning

Position the damper in the opening so that the side of the closing mechanism extends as indicated in the table and in the drawing.

Close the blade before installing the fire damper.

3.10.3. Filling

Fill the space between the wall and the damper as indicated in the table and in the drawing.

Sealing with concrete is not allowed.

	Fire resistance classification	"D" hole size [mm]	Damper protrusion from the wall "E" [mm]	Wall minimum thickness "S" [mm]	Sealing
EI 90 S Installation within vertical light wall (plasterboard)					
Wall rock wool density up to 100 kg/m ³ (optional)	EI 90 S (500 Pa)	Da (Ø + 35) x (Ø + 35) a (B+50) x (H+50) (square hole)	215 + Lp	100	Rock wool 100 kg/m ³ with infill plasterboard (thickness 12.5 mm)
EI 120 S Installation within vertical light wall (plasterboard)					
Wall rock wool density up to 100 kg/m ³ (optional)	EI 120 S (500 Pa)	Da (Ø + 35) x (Ø + 35) to (B+580) x (H+580) (square hole)	215 + Lp	100	Mortar or plaster putty

1. Rock wool density up to 80 kg/m³ (optional)
2. Plasterboard arch infill, thickness 12,5 mm for rock wool sealing
3. Plasterboard thickness 12,5 mm
4. Sealing: see table above
5. Self-drilling screw Ø 3,5 X 45 mm
6. Metal frame

Lp Overlap length between fire damper and duct: see section Dimension [p. 10](#)

D Hole size: see table above

A Distance between vertical profiles: 625 mm see section [Ref] or 312,5 mm see section Construction supports characteristics (special firewall)

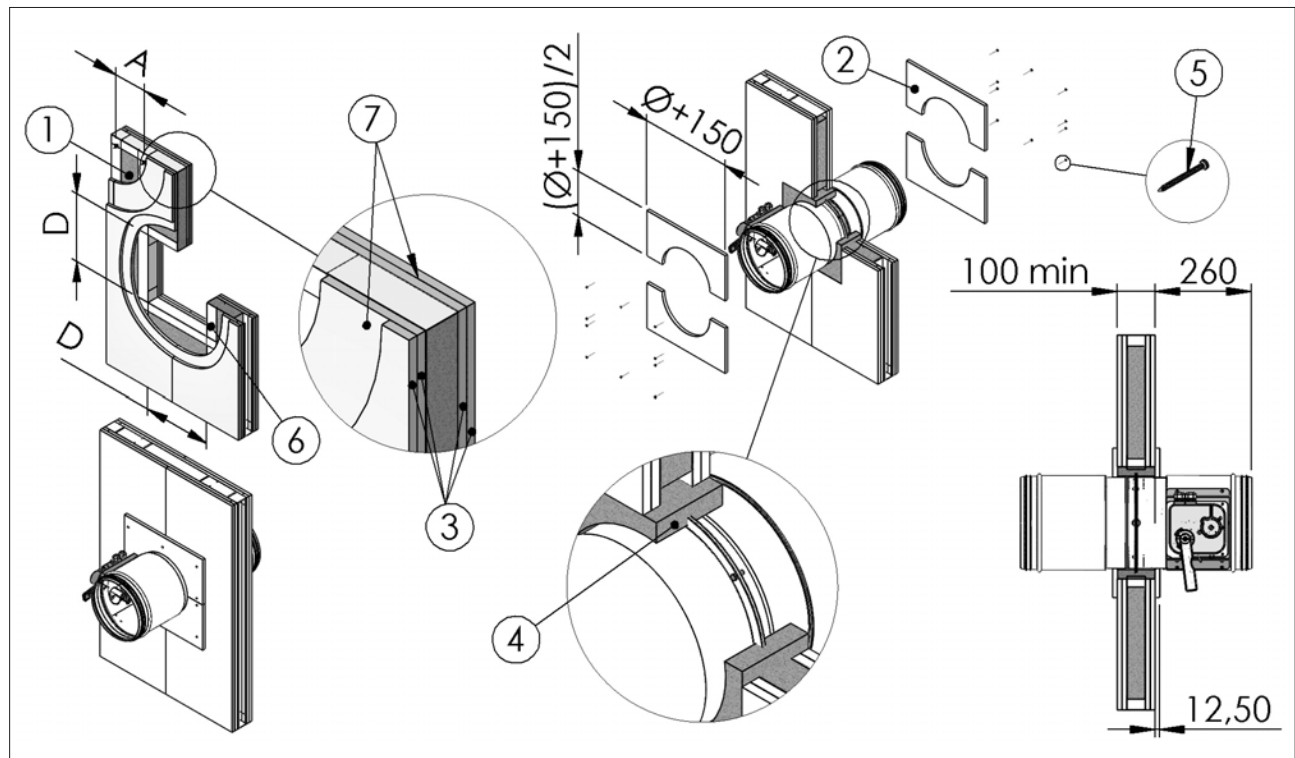

3.11. Installation within vertical light wall (gypsum blocks wall)

Refer to the section Construction supports characteristics (special firewall) [p. 17](#) for further information.

Comply with the minimum distances indicated on section Minimum distances [p. 16](#).

Before and after installation please perform a functional test. Refer to section Mechanism type for further information [p. 7](#).

3.11.1. Wall opening

A opening must be provided in the wall as indicated in the table and in the drawing

3.11.2. Damper positioning

Position the damper in the opening so that the side of the closing mechanism extends as indicated in the table and in the drawing.

Close the blade before installing the fire damper.

3.11.3. Filling

Fill the space between the wall and the damper using plaster putty.

Sealing with concrete is not allowed.

	Fire resistance classification	"D" hole size [mm]	Damper protrusion from the wall "E" [mm]	Wall minimum thickness "S" [mm]	Sealing
EI 90 S Installation within vertical light wall (gypsum blocks wall)					
Wall minimum density 995 kg/m ³	EI 90 S (500 Pa)	Ø + 50 (circular hole)	230 + Lp	70	Plaster putty sealing
EI 120 S Installation within vertical light wall (gypsum blocks wall)					
Wall minimum density 995 kg/m ³	EI 120 S (500 Pa)	From Ø + 25 to Ø+35 (circular hole)	215 + Lp	100	Plaster putty sealing

- 1. Plaster putty
- D Hole size: see table above
- S Wall minimum thickness: see table above

- E Damper protrusion from the wall: see table above
- Lp Overlap length between fire damper and duct: see section Dimension [p. 10](#)

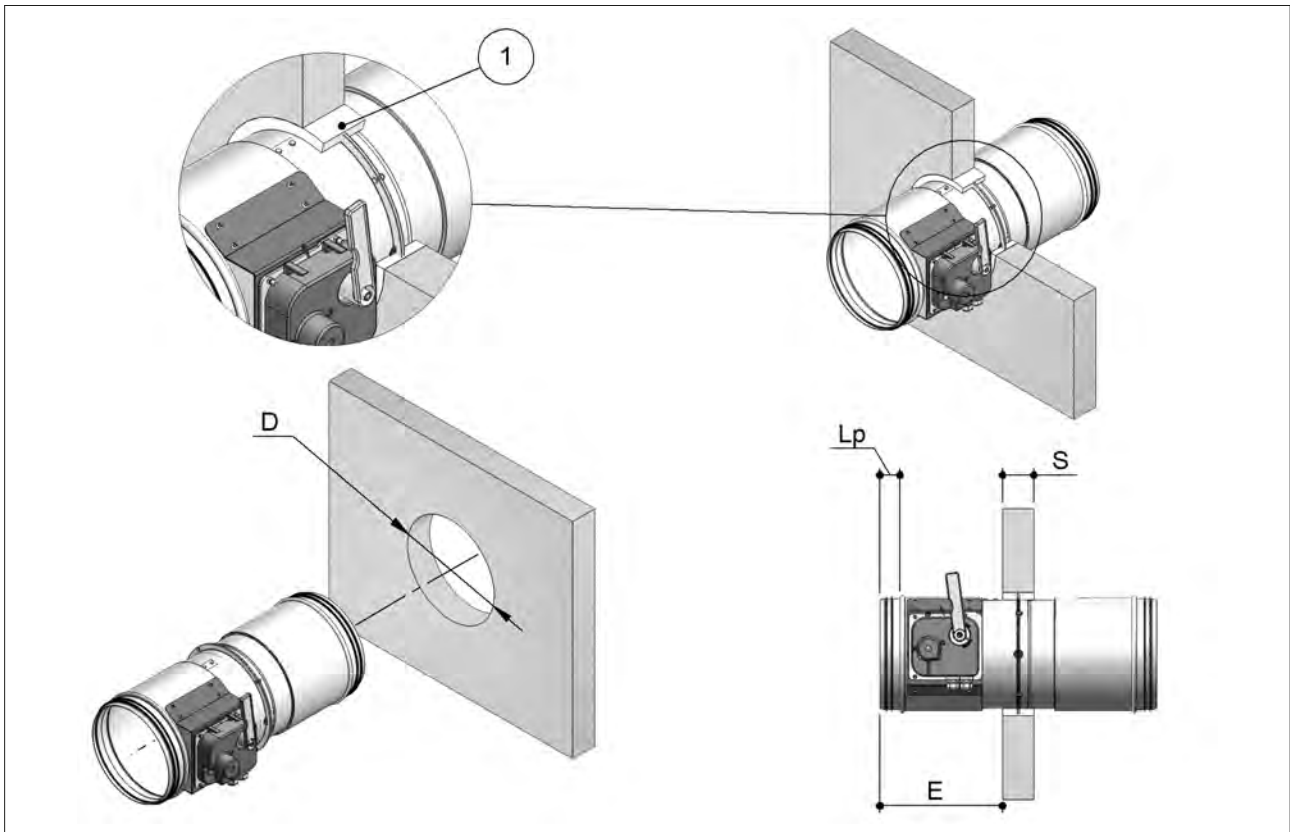

3.12. Installations within floor

Refer to the section [p.17](#) for further information. Comply with the minimum distances indicated on section Minimum distances [p.16](#).

Before and after installation please perform a functional test. Refer to section Mechanism type for further information [p.7](#).

3.12.1. Floor opening

A opening must be provided in the floor as indicated in the table and in the drawing

3.12.2. Damper positioning

Position the damper in the opening so that the side of the closing mechanism extends as indicated in the table and in the drawing.

Close the blade before installing the fire damper.

3.12.3. Filling

Fill the space between the floor and the damper as indicated in the table and in the drawing. Sealing with concrete is not allowed.

	Fire resistance classification	"D" hole size [mm]	Damper protrusion from the floor "E" [mm]	Floor minimum thickness "S" [mm]	Sealing
EI 90 S Installation within floor					
Floor minimum density 650 kg/m ³	EI 90 S (500 Pa)	From Ø + 40 to Ø + 55 (circular hole)	215 + Lp	100	Mortar sealing
EI 120 S Installation within floor					
Floor minimum density 650 kg/m ³	EI 120 S (500 Pa)	From Ø + 40 to Ø + 55 (circular hole)	190 + Lp	150	Mortar sealing
EI 180 S Installation within floor					
Floor minimum density 2200 kg/m ³	EI 180 S (500 Pa)	From Ø + 40 to Ø + 55 (circular hole)	190 + Lp	150	Mortar sealing

- 1. Mortar M-10, EN998-2
- D Hole size: see table above
- S Floor minimum thickness: see table above

- E Damper protrusion from the floor: see table above
- Lp Overlap length between fire damper and duct: see section Dimension [p.10](#)

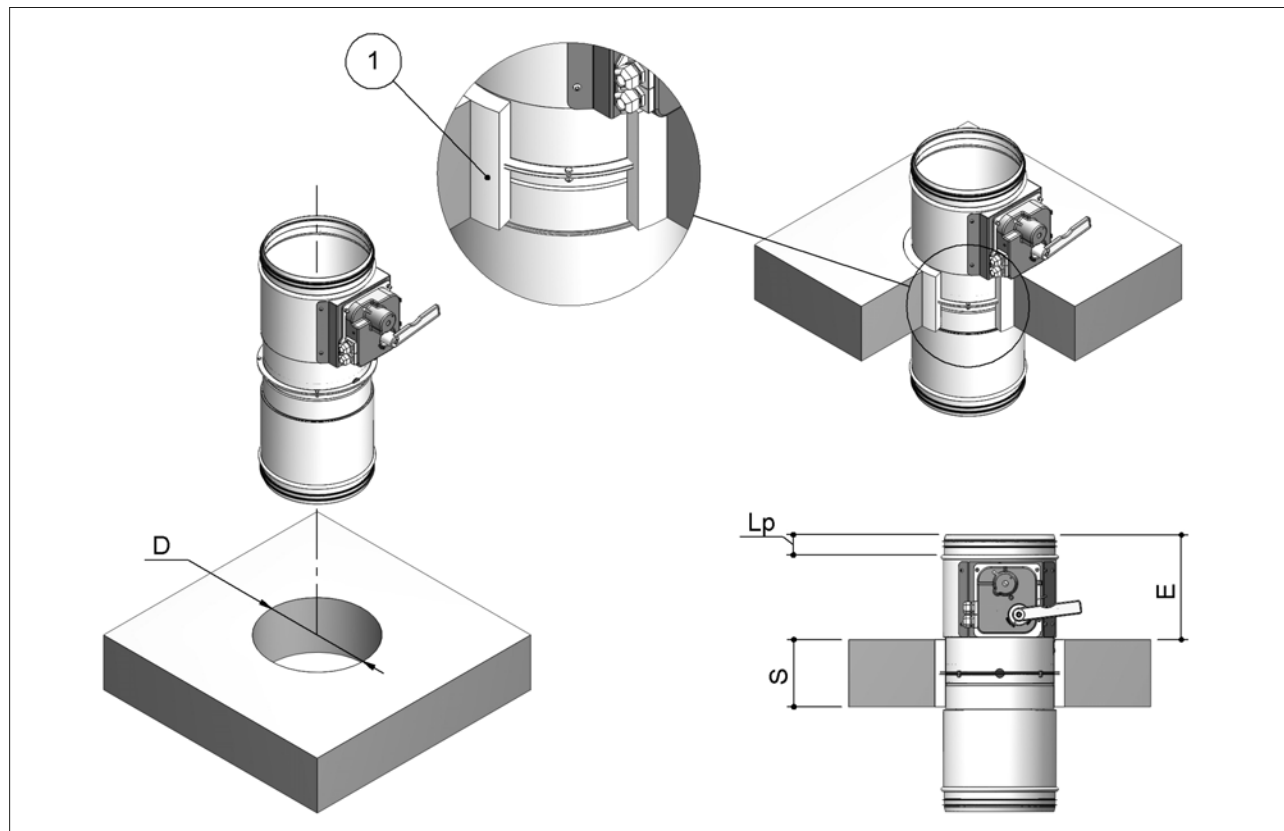

4. ELECTRICAL CONNECTIONS

4.1. Electrical wiring

Electrical connections must be done by qualified and trained people.

Switch off the power supply before starting any work on the electric elements. Never switch on the power supply during electrical connections.

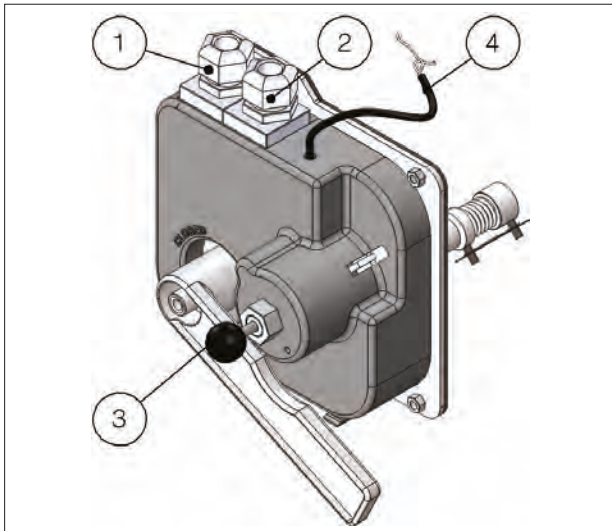

1. SC (closed damper) microswitch - on request
2. SA (open damper) microswitch - on request
3. Magnet - on request
4. Magnet cables for wiring

4.1.1. SC/SA microswitches position

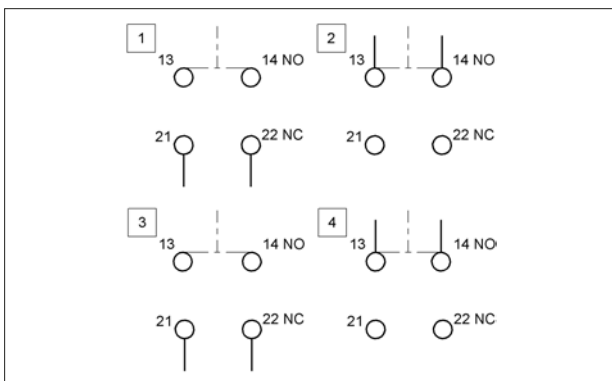

1. "NC" contact of SC microswitch. When the fire blade is closed the circuit is open.
2. "NO" contact of SC microswitch. When the fire blade is closed the circuit is closed.
3. "NC" contact of SA microswitch. When the fire blade is open the circuit is open.
4. "NO" contact of SA microswitch. When the fire blade is open the circuit is closed.

4.1.2. 230 V AC magnet wiring

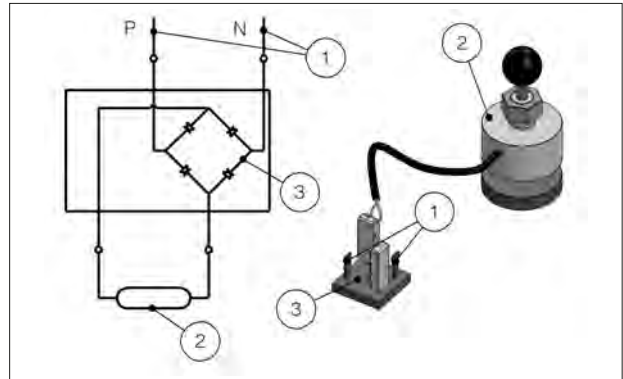

1. 230 V AC power supply
2. Magnet
3. Rectifier

4.1.3. 24 V DC magnet wiring

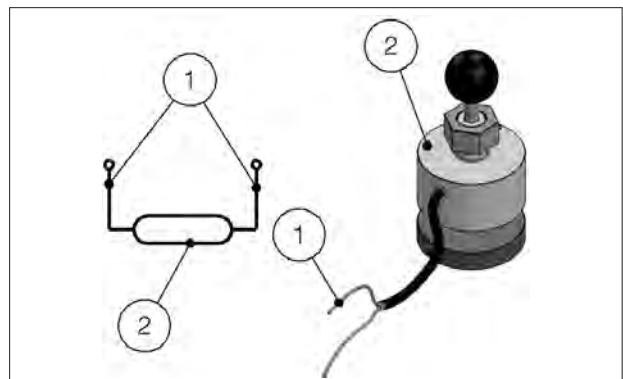

1. 24 V DC power supply
2. Magnet

4.1.4. WH45 - Motorized version

Belimo servomotor:

BFL24T, BFN24T, BF24T, BFL230T, BFN230T, BF230T.

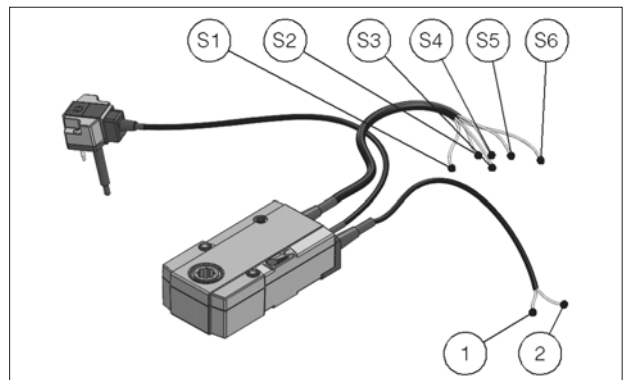

Siemens servomotor:

GRA126, GNA126, GGA126.

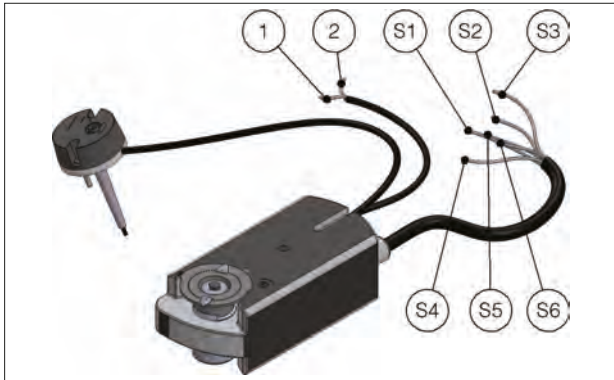

Siemens servomotor:
GRA326, GNA326, GGA326.

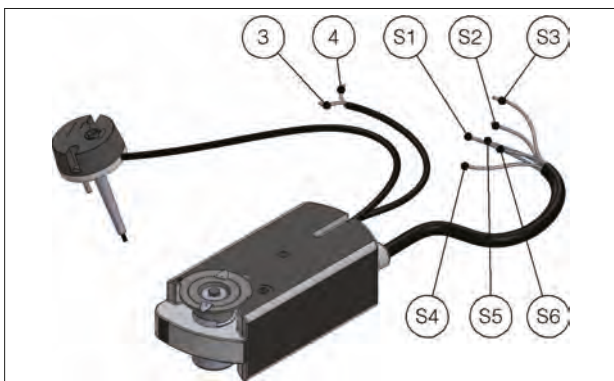

Gruner motor
MT-340TA-024-05-S2-8F; MT-340TA-230-05-S2-8F
MT-360TA-024-12-S2-8F; MT-360TA-230-12-S2-8F
MT-360TA-024-20-S2-8F; MT-360TA-230-20-S2-8F

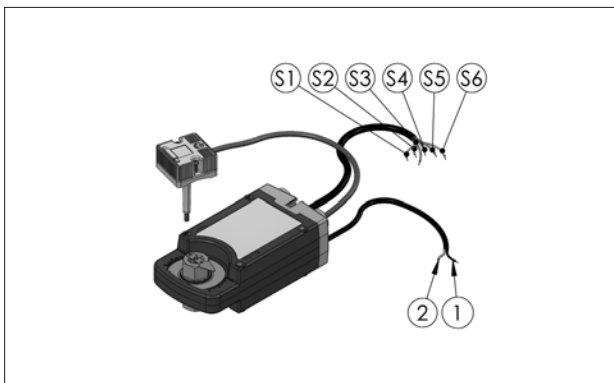

Motorized fire dampers electrical wiring

To connect the dampers to the power supply, proceed as follows:

- Check that the voltage and electrical frequency are equivalent to those of the motor of the servomotor (check the motor's information label);
- Make the connections as shown in the below diagram.

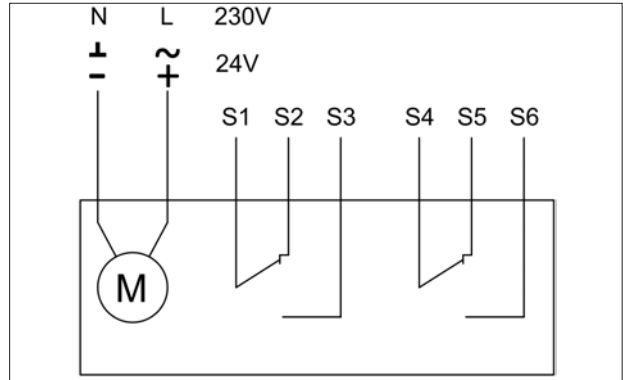

- 1 Negative (DC) or neutral (AC)
- 2 Positive (DC) or phase (AC)
- 3 Phase
- 4 Neutral
- S1 Common closed damper microswitch
- S2 Normally closed, closed damper microswitch
- S3 Normally opened, closed damper microswitch
- S4 Common open damper microswitch
- S5 Normally closed, open damper microswitch
- S6 Normally opened, open damper microswitch

4.2. Electrical specifications

Manual	Manual with magnet
	Belimo motorized version
	Siemens motorized version
	Gruner motorized version
Power interruption magnet:	Power input magnet:
P=4,5 W (24V DC or 230 V AC version) Motor 24V AC/DC (WH45VMB):	P=4,5 W (24V DC or 230 V AC version) Motor 230V AC (WH45DMB):
Belimo BFN24T	Belimo BFN230T
Opening: 4 W	Opening: 5 W
In stand-by: 1,4 W Motor 24V AC/DC (IWH45VGB):	In stand-by: 2,1 W Motor 230V AC (WH45DGB)
Belimo BF24T	Belimo BF230T
Opening: 7 W	Opening: 8 W
In stand-by: 2 W Motor 24V AC/DC (WH45VPS) / (WH45VSS):	In stand-by: 3 W Motor 230V AC (WH45DPS) / (WH45DSS):
Siemens GNA126 / GRA126	Siemens GNA326 / GRA326
Opening: 3,5 W	Opening: 4,5 W
In stand-by: 2 W Motor 24V AC/DC (WH45VGS):	In stand-by: 3,5 W Motor 230V AC (WH45DGS):
Siemens GGA126	Siemens GGA326
Opening: 6 W	Opening: 6 W
In stand-by: 1.5 W	In stand-by: 2,5 W
Gruner MT-340TA-024-05-S2-8F	Gruner MT-340TA-230-05-S2-8F
Opening: 6,5 W	In apertura: 5,5 W
In stand-by: 2 W Motor 24V AC/DC (WH45VGS):	In stand-by: 2 W Motor 230V AC (WH45DGS):
Gruner MT-340TA-024-12-S2-8F	Gruner MT-340TA-230-12-S2-8F
Opening: 5 W	In apertura: 5,5 W
In stand-by: 2,0 W Motor 24V AC/DC (WH45VGS):	In stand-by: 1.5 W Motor 230V AC (WH45DGS):
Gruner MT-340TA-024-20-S2-8F	Gruner MT-340TA-230-20-S2-8F
Opening: 10,5 W	Opening: 10,5 W
In stand-by: 2,5 W Motor 24V AC/DC (WH45VGS):	In stand-by: 2,5 W Motor 230V AC (WH45DGS):

Voltage and power consumption

		Manual	
		Manual with magnet	
		Belimo motorized version	
		Siemens motorized version	
		Gruner motorized version	
	Manual control version:	Motorized version:	
	15 - 400V	Siemens: AC 24V...230V / 6 (2) A	
Microswitches position contacts	1,8 A	Belimo: DC 5V...AC 250V / 1mA...3A (0,5A)	
		Gruner: DC 5V...AC 250V / 1mA...5A (2,5A)	
Blade closing time	Spring: 1 s	motor: < 30 s	
Protection degree	IP42	IP42 MAGNETIC VERSION	
		IP54 MOTORIZED VERSION	

5. MAINTENANCE AND INSPECTIONS

Fire dampers and control mechanisms do not require routine maintenance.

Extraordinary maintenance (repairs) and periodic inspection operations are the responsibility of the ventilation system operator.

It is recommended to keep enough space (about 200mm) for using or replacing the control mechanism or for maintenance. Also provide the necessary space to remove the ventilation duct from the damper whenever necessary.

It is recommended to provide inspection hatches on both sides of the ducts connected to the fire damper.

The implementation of a periodic inspection plan allows to guarantee the efficiency and functionality of the fire dampers for the fire safety of the building.

5.1. Periodic inspection and cleaning

Periodic inspection shall be performed in accordance with the requirements of the law or by the building regulations or other local regulations.

In the absence of specific regulations (or to their complement), in accordance with point 8.3 of the EN 1560 standard, it is recommended to carry out the following control activities at intervals of no more than 12 months:

- Check the servomotor electrical wiring for damage (where applicable);
- Check end-switch wiring for damage (where applicable);
- Check damper cleanliness and clean where necessary;
- Check the condition of blades and seals, rectify and report where necessary;
- Check the correct opening and closing of the fire damper by manual operation according to the instructions in the technical manual of the fire damper;
- Check the opening and closing operation of the damper controlled by the fire alarm system (if present);
- Check the operation of the end switches in open and closed state, adjust and report if necessary;
- Confirm that the damper fulfils its function as part of the control system (where necessary);
- Check that the damper is left in its normal operating position, which usually corresponds to the open position.

5.2. Repair

For safety reasons, repair activities involving fire-fighting components must be carried out only by qualified personnel.

Only original spare parts supplied by the fire damper manufacturer must be used.

A functional test must be performed after each repair.

At the end of the inspection, cleaning or repair operations, check that the fire damper is in the normal operating position.

Keep records of all inspections, repair activities, any problems encountered and their resolution.

This practice, even when not mandatory, is very useful in practice.

5.3. Disposal

Disposal in case of destruction must be carried out in accordance with national legislation. For electrical and electronic parts also refer to EU Directive 2011/65.

6. SELECTION

6.1. Air flow rates in relation to the diameter

Maximum frontal air speed = 15 m/s

\emptyset mm	Front section m ²	Net section m ²	Maximum air flow m ³ /h
200	0,031	0,023	1696
250	0,049	0,039	2649
300	0,071	0,059	3815
315	0,078	0,065	4206
355	0,099	0,085	5342
400	0,126	0,110	6782
450	0,159	0,141	8584
500	0,196	0,176	10598
560	0,246	0,224	13294
600	0,283	0,259	15260
630	0,312	0,286	16825
710	0,396	0,367	21369
800	0,502	0,470	27130

6.2. Air flow rates as a function of the pressure drop

\emptyset mm	ΔP 20 Pa		ΔP 30 Pa		ΔP 40 Pa	
	Q m ³ /h	Lw dB(A)	Q m ³ /h	Lw dB(A)	Q m ³ /h	Lw dB(A)
200	618	43,8	757	49,9	874	54,3
250	1149	45,8	1408	52,0	1625	56,3
300	1908	47,5	2336	53,7	2698	58,0
315	2185	48,0	2676	54,1	3090	58,5
355	3046	49,1	3730	55,2	4307	59,6
400	4244	50,2	5198	56,3	6002	60,7
450	5888	51,3	7211	57,4	8326	61,8
500	7891	52,2	9664	58,4	>Qmax	--
560	10812	53,3	13242	59,4	>Qmax	--
600	13098	53,9	>Qmax	--	>Qmax	--
630	15000	54,4	>Qmax	--	>Qmax	--
710	20912	55,5	>Qmax	--	>Qmax	--
800	>Qmax	--	>Qmax	--	>Qmax	--

6.3. Air flow rates as a function of generated sound levels

\emptyset mm	Lw 35 dB(A)		Lw 40 dB(A)		Lw 45 dB(A)	
	Q m ³ /h	ΔP Pa	Q m ³ /h	ΔP Pa	Q m ³ /h	ΔP Pa
200	463	11,2	546	15,6	644	21,7
250	804	9,8	948	13,6	1118	18,9
300	1262	8,8	1489	12,2	1755	16,9
315	1424	8,5	1680	11,8	1981	16,4
355	1915	7,9	2258	11,0	2663	15,3
400	2572	7,3	3034	10,2	3577	14,2
450	3443	6,8	4060	9,5	4788	13,2
500	4469	6,4	5270	8,9	6215	12,4
560	5915	6,0	6976	8,3	8227	11,6
600	7017	5,7	8275	8,0	9758	11,1
630	7917	5,6	9337	7,7	11011	10,8
710	10643	5,2	12551	7,2	14801	10,0
800	14300	4,8	16864	6,7	19887	9,3

6.4. Pressure drop and sound level graph Ø 200-560

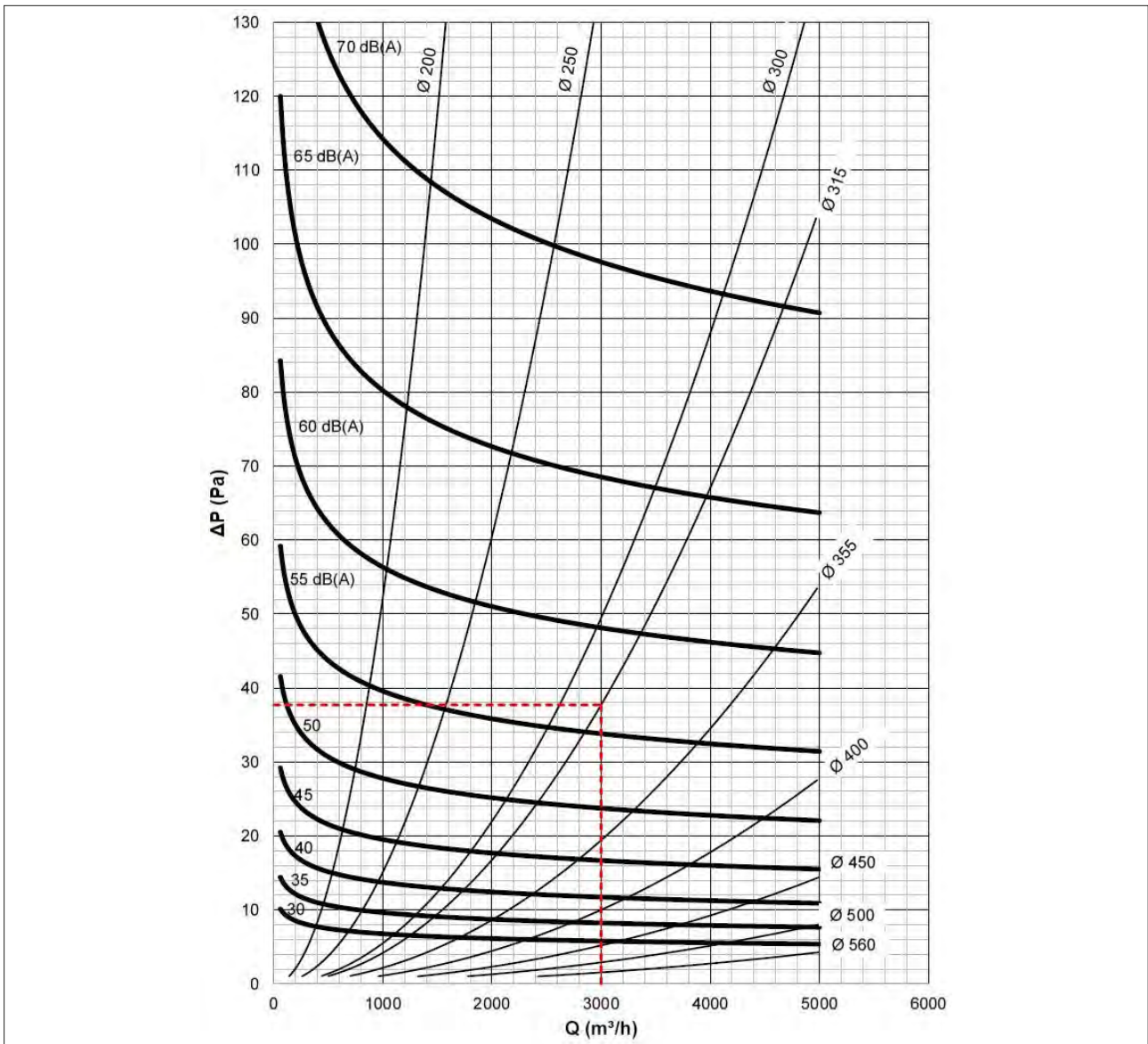

Example

Ø = Diameter [mm]	Ø = 315 mm
Q = Air flow [m³/h]	Q = 3000 m³/h
V1 = Frontal air speed [m/s]	V1 = 10,7 m/s
ΔP = Pressure drop [Pa]	From graph: ΔP = 37,7 Pa
Lw = Sound level [dB(A)]	From graph: Lw = 56 dB(A)

6.5. Pressure drop and sound level graph Ø 450-800

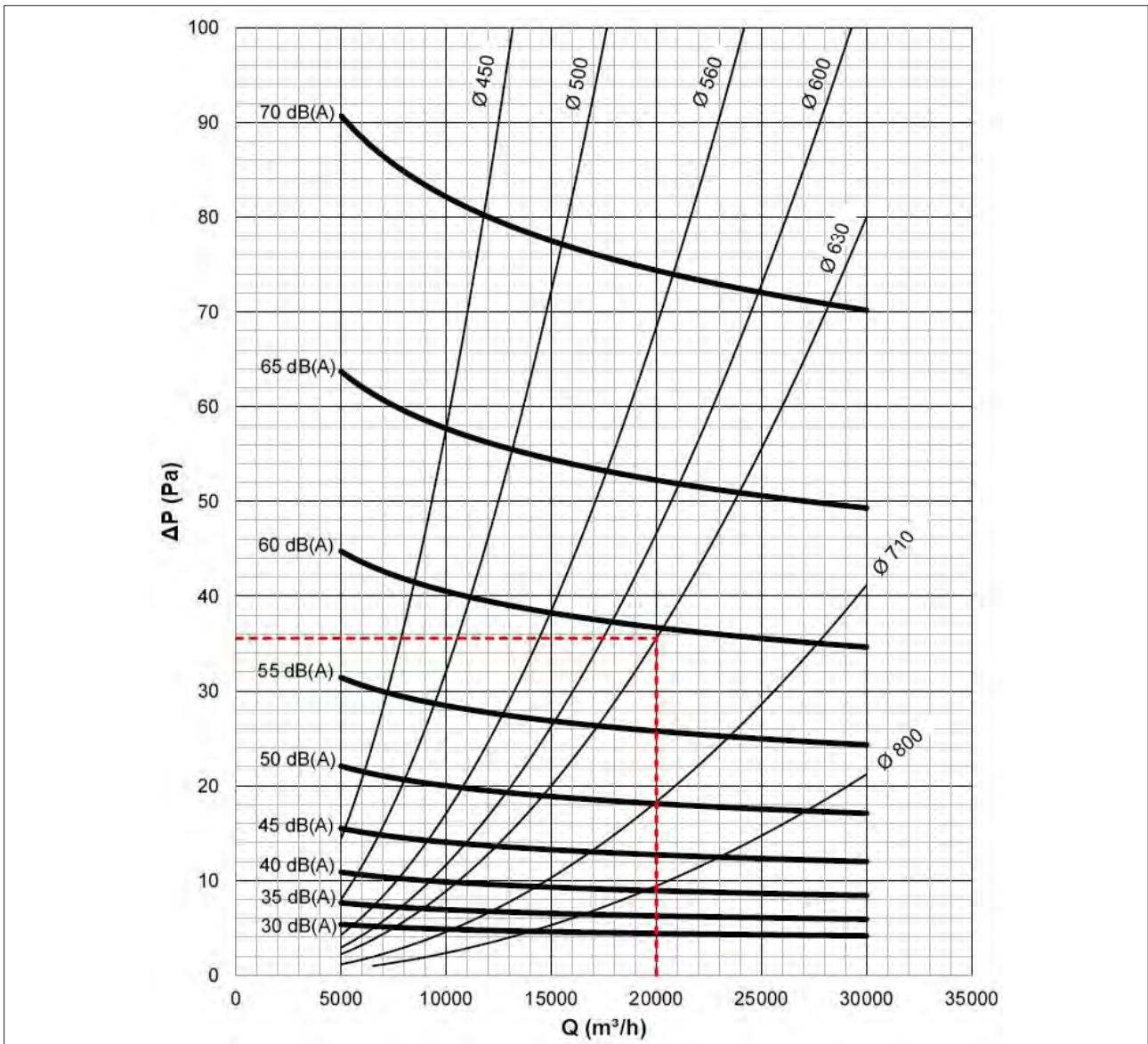

Example

Ø = Diameter [mm]	Ø = 630 mm
Q = Air flow [m³/h]	Q = 20000 m³/h
V1 = Frontal air speed [m/s]	V1 = 17,8 m/s
ΔP = Pressure drop [Pa]	From graph: ΔP = 36 Pa
Lw = Sound level [dB(A)]	From graph: Lw = 59 dB(A)

6.6. Sound spectrum table

Correction used to estimate the octave band spectrum (Values to be added to the noise levels in dB(A))								
Frontal speed	Frequency Hz							
m/s	63	125	250	500	1000	2000	4000	8000
6	15	7	4	-4	-9	-10	-15	-22
9	17	8	5	-4	-9	-10	-19	-20
12	20	9	5	-4	-9	-15	-16	-12

7. ACCESSORIES AND SPARE PARTS

	Arch infill panels for plasterboard installation from Ø 200 to Ø 800	TAMP-WH45-Ø
	Open blade microswitch Closed blade microswitch (necessary according to UNI 10365, art. 4.9)	WHKICKIT WHKFKKIT
	Remote control magnet, optional for manual command fire dampers. Power supply input version: the fire damper blade closes when power is supplied. Power supply 24 V DC - 4,5 W Remote control magnet, optional for manual command fire dampers. Power supply input version: the fire damper blade closes when power is supplied. Power supply 230V DC - 4,5 W - rectifier included	WHKMA024KIT WHKMA230KIT
	Remote control magnet, optional for manual command fire dampers. Power supply interruption version: the fire damper blade closes when power is not supplied. Power supply 24 V DC - 4,5 W Remote control magnet, optional for manual command fire dampers. Power supply interruption version: the fire damper blade closes when power is not supplied. Power supply 230 V DC - 4,5 W - rectifier included	WHKMG024KIT WHKMG230KIT
	WH45 manual mechanism with fuseholder group, cam, lever, protection box and 4 fixing nuts for Ø ≤ 315 WH45 manual mechanism with fuseholder group, cam, lever, protection box and 4 fixing nuts for Ø ≤ 315	WH45MAN3 WH45MAN4
	WH45 manual mechanism with fuseholder group, cam, lever, protection box 4 fixing nuts and 1 microswitch closed damper for Ø ≤ 315 WH45 manual mechanism with fuseholder group, cam, lever, protection box 4 fixing nuts and 1 microswitch closed damper for Ø > 315	WH45MAN3CM WH45MAN4CM
	Red reset lever for WH/WK45 (spare part for manual mechanism) Blue reset lever for WH/WK45 (spare part for manual mechanism)	WHK45PLSLEVA WHK45PLSLEVAB
	Motorized plate WH45/43 for Siemens GGA + fixing screws (motor not included)	WK45MGMU

	Belimo motor for dampers predisposed for use with BFN24T / BF24T, 24 V AC/DC power supply, thermofuse 72 °C	BFN24T/BF24T
	Belimo motor for dampers predisposed for use with BFN24T-ST / BF24T-ST, 24 V AC/DC power supply, thermofuse 72 °C with connection plugs for control and monitoring systems	BFN24T-ST / BF24T-ST
	Belimo motor Top Line series for dampers predisposed for use with BF24TLT-ST, 24 V AC/DC power supply, thermofuse 72 °C with connection plugs for control and monitoring systems	BF24TLT-ST
	Belimo motor for dampers predisposed for use with BFN230T / BF230T, 230 V AC power supply, thermofuse 72 °C	BFN230T / BF230T
	Siemens motor for dampers predisposed for use with GGA126 / GNA126 / GRA126, 24 V AC/DC power supply, thermofuse 72 °C	GGA126 / GNA126 / GRA126
	Siemens motor for dampers predisposed for use with GGA326 / GNA326 / GRA326, 230 V AC power supply, thermofuse 72 °C	GGA326 / GNA326 / GRA326
	Gruner motor for dampers predisposed for use with 340TA-024-05-S2-8F, 24 V AC/DC power supply, thermofuse 72 °C	VSG 340 -340TA-024-05-S2-8F
	Gruner motor for dampers predisposed for use with 340TA-230-05-S2-8F, 230 V AC/DC power supply, thermofuse 72 °C	DSG 340 -340TA-230-05-S2-8F
	Gruner motor for dampers predisposed for use with 360TA-024-12-S2-8F, 24 V AC/DC power supply, thermofuse 72 °C	VSG 360 -360TA-024-12-S2-8F
	Gruner motor for dampers predisposed for use with 360TA-230-12-S2-8F, 230 V AC/DC power supply, thermofuse 72 °C	DSG 360 -360TA-230-12-S2-8F
	Gruner motor for dampers predisposed for use with 360TA-024-20-S2-8F, 24 V AC/DC power supply, thermofuse 72 °C	VSG 360 - MT-360TA-024-20-S2-8F
	Gruner motor for dampers predisposed for use with 360TA-230-20-S2-8F, 230 V AC/DC power supply, thermofuse 72 °C	DSG 360 - MT-360TA-230-20-S2-8F
	Copper mechanical thermofuse 70 °C for manual mechanism	WK70
	Copper mechanical thermofuse 95 °C for manual mechanism	WK95
	Thermofuse 72 °C for Belimo motor BFL, BFN and BF (spare part)	WWEZBAT72
	Thermofuse 95 °C for Belimo motor BFL, BFN and BF (accessory)	WWEZBAT95
	Thermofuse 72 °C for Siemens motors GRA, GNA and GGA (spare part)	MT-FUSASK79.4
	Thermofuse 95 °C for Siemens motors GRA, GNA and GGA (accessory)	MT-FUSASK79.5
	Thermofuse 72 °C for Gruner motor 340TA-024-05-S2 e 340TA-230-05-S2 (Spare part)	TAE-72
Thermofuse 95 °C for Gruner motor 340TA-024-05-S2 e 340TA-230-05-S2 (Spare part)	TAE-95	
	Matt black epoxy powder painting for WH45 fire damper casing Attention: Lindab Safe connectors can't be painted.	WH45PAINT[Ø]
	<ul style="list-style-type: none"> • Corrosion resistance: Excellent • Heat resistance: Very good • Resistance direct impact: ≥2Kg 5cm ISO 6272 • Resistance reverse impact: ≥2Kg 5cm ISO 6272 • Resistance umidity chamber: after 500 hrs noy blistering ISO 6270 • Resistance salt spray test: after 500 hrs creeping at cross-cut <1mm ISO 9227 	
	Communication and control unit BKS24-1B to control and monitor 1 fire damper with Belimo motor	WHBKS241B
	Communication and control unit BKS24-9A to control and monitor up to 9 fire dampers with Belimo motor	WHBKS249A



Communication and power supply unit: BKN230-24 for Belimo motors BFL24T-ST, BFN24T-ST e BF24T-ST	WHBKN23024
LON Communication and power supply unit: BKN230-24LON for Belimo motors BF24TL-T-ST	WHKBKN230-24LON
Modbus Communication and power supply unit: BKN230-24MOD for Belimo motors BFL24T-ST, BFN24T-ST and BF24T-ST	WHKBKN230-24MOD
Communication and power supply unit MPBUS for BKS24-9A or gateways Belimo UK24MOD and UK24BAC: BKN230-24-C-MP for Belimo motors BFL24T-ST, BFN24T-ST and BF24T-ST	WHKBKN230-24-C-MP
Modbus Communication and power supply unit: BKN230MOD for Belimo motors BFL230T, BFN230T and BF230T	WHKBKN230MOD



Gateway UK24BAC Belimo for BACnet communication	WHKUK24BAC
---	------------

(1) It is recommended to foresee the position microswitches for the manual fire dampers with magnet.

8. HOW TO ORDER

8.1. Motorized fire dampers

Code		
Type	WH	Circular fire damper
Series	45	Blade thickness 40 mm - 500 Pa air sealing
Motor type	VSSM	Siemens motor GRA126 (24V)
	DSSM	Siemens motor GRA326 (230V)
	VPSM	Siemens motor GNA126 (24V)
	DPSM	Siemens motor GNA326 (230V)
	VMBM	Belimo motor BFN24T (24V)
	DMBM	Belimo motor BFN230T (230V)
	TMBM	Belimo motor BFN24T-ST (24V) with connection plugs for integration in control and monitoring systems
	VGSM	Siemens motor GGA126 (24V)
	DGSM	Siemens motor GGA326 (230V)
	VGBM	Belimo motor BF24T (24V)
	DGBM	Belimo motor BF230T (230V)
	TGBM	Belimo motor BF24T-ST (24V) with connection plugs for integration in control and monitoring systems
	VSGM	Gruner motor 340 TA24-05-S2 (24V)
	DSGM	Gruner motor 340 TA230-05-S2 (230V)
	VMGM	Gruner motor 360TA-24-12-S2 (24V)
	DMGM	Gruner motor 360TA-230-12-S2 (230V)
VGGM	Gruner motor 360 TA-24-12-S2 (24V)	
DGGM	Gruner motor 360 TA 230 20 S2 (230V)	
Dimension	XYZ	Nominal diameter (mm)

8.2. Fire damper with manual control

Code		
Type	WH	Circular fire damper
Series	45	Blade thickness 40 mm - 500 Pa air sealing
Command type	B	Manual command
	M	Manual command with magnet
Position indication microswitches	S0	Without position microswitches (not recommended)
	SA	With open blade microswitch
	SC	With closed blade microswitch
	S2	With two microswitches
	M0	Without magnet (only for command type "B")
Magnet	MR	With power supply interruption magnet, 24 V DC
	MI	With power supply input magnet, 24 V DC
	MY	With power supply interruption magnet, 230 V AC
	MZ	With power supply input magnet, 230 V AC
Dimension	XYZ	Nominal diameter (mm)

Examples	Code
WH45 fire damper with manual control, Ø 200	WH45B-S0-M0-200
WH45 fire damper with manual control and two microswitches, Ø 500	WH45B-S2-M0-500
WH45 fire damper with manual control, 24 V DC power interruption magnet, with closed blade microswitch, Ø 315	WH45M-SC-MR-315
WH45 fire damper with manual control, 24 V DC power input magnet, with two microswitches, Ø 800	WH45M-S2-MI-800
WH45 Siemens motorized 230V fire damper, Ø 250	WH45DPSM-250

8.3. Electric motor driven actuators

Motor type	Diameters													
	200	250	300	315	355	400	450	500	560	600	630	710	800	
Belimo	M	M	M	M	M	M	M	M	M	M	M	M	G	G
Siemens	S	S	S	S	P	P	P	P	P	P	P	P	G	G
Gruner	S	S	S	S	S	S	S	M	M	M	M	M	M	M

	BELIMO		SIEMENS		GRUNER	
	24V	230V	24V	230V	24V	230V
S	-	-	GRA126	GRA326	340TA-024-05-S2	340TA-230-05-S2
P	-	-	GNA126	GNA326	-	-
M	BFN24T	BFN230T	-	-	360TA-024-12-S2	360TA-230-12-S2
G	BF24T	BF230T	GGA126	GGA326	360TA-024-20-S2	360TA-230-20-S2

9. SPECIFICATION TEXT

9.1. Series WH45 circular fire damper

Description

WH45 circular fire damper tested for fire resistance and smoke seal with 500 Pa depression as per EN 1366-2, classified according to EN 13501-3 and CE marked according to European Regulation UE 305/2011 and EN 15650 standard. Allows maximum safety for fire protection inside buildings providing perfect heat insulation and cold and hot smokes tightness. Can be connected to fire protection alarm system or smokes detection to anticipate blade closure before fire, prevents indirect damages caused by smokes generated by combustion.

Technical characteristics

- Available diameters from 200 to 800 mm
- Case made from galvanized sheet steel, with a total length of 620 mm in 2 parts joined with bolts and mineral fiber sealing
- Closing mechanism built according to UNI 10365, with thermal fuse certified to ISO 10294-4, a test button to check the correct working of the damper, a release system to block the damper in closed position and a visual signal "open/closed". The closing mechanism can be easily interchanged and substituted:
 - with mechanical release and manual rearming
 - with mechanical release and manual rearming, can be released remotely via a magnet and electric and signal
 - with electric release and rearming, via and integrated Siemens or Belimo system tested according to EN 15650, composed by an electric thermal fuse and remote controlled servomotor via an electrical signal
- Blade damper made from calcium silicate material, complete with elastomer lip gasket for the air seal of cold smoke, as per EN 1366-2
- Blade axis made of steel, patented fixing on casing, with low friction bearings for high reliability in case of fire.
- Thermal, expanding graphite gasket
- Thermal fuse with melting point certified ISO 10294-4 at 70 °C or 95 °C (version with mechanical release) or at 72 °C (version with servo motor)
- Absence of thermal bridge between the wall of installation and the ducts before and after
- Resistance to salt spray, tested with severity 2, according to EN 60068-2-52
- Casing leakage class C for diameter bigger than 315 mm as per EN 1751. Casing leakage class B minimum for diameter less than or equal to 315 mm as per EN 1751 (class C on request).

Installation

- Installation within vertical rigid walls made from aerated concrete blocks, standard concrete or masonry with a minimum thickness of 100 mm and minimum density of 500 kg/m³:
 - with mortar or plaster putty sealing (EI 120 S)
 - with plasterboard and rock wool 100 kg/m³ sealing (EI 90 S)
- Installation within light plasterboard walls with minimum thickness of 100 mm (EI 90 S)

- Installation within light walls made with gypsum blocks 100 mm thick and minimum density 995 kg/m³ (EI 120 S) or minimum thickness of 70 mm and minimum density 995 kg/m³ (EI 90 S)
- Installation within concrete floors with a minimum thickness of 150 mm and minimum density of 2200 kg/m³ (EI 180 S) or aerated concrete with minimum thickness 150 mm and minimum density 650 kg/m³ (EI 120 S) or aerated concrete with minimum thickness 100 mm and minimum density 650 kg/m³ (EI 90 S)
- Fire resistance characteristics independent from direction of the source of the fire according to EN 1366-2 article 6.2
- Installation possible with damper blade placed horizontally or vertically, with the mechanism placed in left/right or above/below

Accessories

- Motorised version with 24 V or 230 V servomotor installed on the damper
- Set of microswitches with four NO/NC position detecting connectors for open and closed damper, as per standard UNI 10365
- Immission and interruption magnet 24 V DC or 230 V AC with rectifier
- Power supply and communication unit LonWorks, MP-Bus, Modbus, Bacnet

10. REVISION INDEX

Revision n°	Date of issue	Description
14/00	2014/11	First issue
15/07	2015/07	<p>Added section:</p> <ul style="list-style-type: none"> • Blade rotation axis positioning p. 12 <p>Added table:</p> <ul style="list-style-type: none"> • Revision Index p. 38 <p>Updated drawing:</p> <ul style="list-style-type: none"> • El 90 S Installation within vertical light wall (plasterboard) p. 21 <p>Updated section:</p> <ul style="list-style-type: none"> • Belimo motorized version p. 7 • Specification Text p. 37 <p>Updated table:</p> <ul style="list-style-type: none"> • Fire resistance classification according to EN 13501-3-2009 p. 5 • Performances p. 5 • Accessories and spare parts p. 32 • Motorized fire dampers p. 35 <p>General improvements</p>
16/04	2016/04	<p>Updated section:</p> <ul style="list-style-type: none"> • Mechanism type p. 7 • Technical data p. 10 • Electrical connections p. 24 • How to order p. 35 <p>Updated table:</p> <ul style="list-style-type: none"> • Fire resistance classification according to EN 13501-3-2009 p. 5 • Accessories and spare parts p. 32 <p>General improvements</p>
16/10	2016/10	<p>Added section:</p> <ul style="list-style-type: none"> • Indications for the correct duct suspension and for damper connection • Positioning brackets before fixing (if required) p. 12 • El 90 S Installation within vertical rigid wall p. 19 <p>Updated section:</p> <ul style="list-style-type: none"> • Fire resistance classification according to EN 13501-3-2009 p. 5 • Minimum distances p. 16 • Mechanism type p. 7 <p>Updated table:</p> <ul style="list-style-type: none"> • Accessories and spare parts p. 32 <p>General improvements</p>
17/04	2017/04	<p>Updated section:</p> <ul style="list-style-type: none"> • p. 21 • Maintenance and inspections p. 28 <p>Updated table:</p> <ul style="list-style-type: none"> • Electrical specifications p. 26 • Motorized fire dampers p. 35 • Electric motor driven actuators p. 36 • Accessories and spare parts p. 32 <p>General improvements</p>
19/05	2019/05	<p>Added section:</p> <ul style="list-style-type: none"> • Installation of flexible connectors in order to balance out the ventilation ducts expansion p. 12 • Transfer Application (application not connected to air ducts on one or both sides) p. 14 <p>Updated section:</p> <ul style="list-style-type: none"> • Installation p. 12 • Not allowed uses p. 12 • Minimum distances p. 16 • Light plasterboard vertical walls p. 17 • Maintenance and inspections p. 28 • Accessories and spare parts p. 32 <p>Updated table:</p> <ul style="list-style-type: none"> • Installations within vertical rigid wall p. 19 • p. 21 <p>General improvements</p>

Revision n°	Date of issue	Description
20/10	2020/10	Updated section: Installation of flexible connectors in order to balance out the ventilation ducts expansion p. 12 Not allowed uses p. 12 Transfer Application (application not connected to air ducts on one or both sides) p. 14 Mechanism type p. 7 Installation p. 12 Minimum distances p. 16 Periodic inspection and cleaning p. 28 Updated table: Installations within vertical rigid wall p. 19 Updated drawing: Installations within vertical rigid wall p. 19 General improvements
22/06	2022/06	Updated section: Mechanism type p. 7 Minimum distances p. 16 Updated table: Dimension Accessories and spare parts p. 32 General improvements



As the manufacturer is constantly improving its products, the aesthetic or dimensional features, the technical data, the equipment and accessories indicated could be subject to variations.