



Serie FBC

1-4-7



TECHNICAL MANUAL INSTALLATION TYPE
WITH FIRE RESISTANCE CLASS
ENGLISH
FIRE DAMPER CIRCULAR
SERIES FBC 1 - 4 - 7 - 300 PACERT.
N° 1812-CPR-1630 - 1812-CPR-1632 - 1812-CPR-1634



☎ +34913235805

✉ info@difair.es

🌐 www.difair.es



1. Overview	p. 4
1.1. Description	p. 4
1.2. General characteristics	p. 4
1.3. European Standards applied	p. 4
1.4. Certifications and approvals	p. 4
1.5. Components	p. 4
1.6. Available dimensions	p. 4
1.7. Performances	p. 4
1.8. Fire resistance classification according to EN 13501-3-2009	p. 5
1.9. Mechanism type	p. 8
2. Technical data	p. 10
2.1. Dimension	p. 10
2.2. Weights	p. 10
3. Installation	p. 11
3.1. Intended use	p. 11
3.2. Not allowed uses	p. 11
3.3. Blade rotation axis positioning	p. 11
3.4. Installation of flexible connectors in order to balance out the ventilation ducts expansion	p. 11
3.5. Minimum distances	p. 12
3.6. Construction supports characteristics	p. 13
3.7. Installations within vertical rigid wall	p. 14
3.8. Installations within vertical light wall (plasterboard)	p. 22
3.9. Installations within floor	p. 36
3.10. Installations within vertical wall with Fire Batt (Weichschott) sealing	p. 37
3.11. Installation within floor with Fire Batt (Weichschott) sealing	p. 38
4. Electrical connections	p. 39
4.1. Electrical wiring	p. 39
5. Maintenance and inspections	p. 40
5.1. Periodic inspection and cleaning	p. 40
5.2. Repair	p. 40
5.3. Disposal	p. 40
6. Selection	p. 41
6.1. Air flow rates in relation to the diameter	p. 41
6.2. Air flow rates as a function of the pressure drop	p. 41
6.3. Air flow rates as a function of generated sound levels	p. 41
6.4. Pressure drop and sound level graph	p. 42
6.5. Sound spectrum table	p. 43
7. Accessories and spare parts	p. 44
8. How to order	p. 45
9. Specification Text	p. 46
9.1. Circular fire damper series FBC Butterfly	p. 46
10. Revision Index	p. 47

1. OVERVIEW

1.1. Description

Fire dampers FBC are devices for use in heating, ventilation and air-conditioning (HVAC) systems at fire boundaries to maintain compartmentation and protect means of escape in case of fire. They satisfy integrity, insulation and smoke leakage criteria for the declared time of fire resistance. Tested and classified in accordance with EN 1366-2 and EN 13501-3 standards with 300 Pa depression.

1.2. General characteristics

- Casing made from galvanized carbon steel.
- Air duct connection gasket.
- Intumescent sealing gasket.
- Automated closing mechanism.
- 10 mm thick closing blade made with refractory material.
- Blade lip seal for cold smoke seal.

1.3. European Standards applied

CE certification	EN 15650
Test	EN 1366-2
Classification	EN 13501-3
Thermal fuse reliability	ISO 10294-4

1.4. Certifications and approvals

CE Certificate of Constancy of Performance	FBC1: n° 1812-CPR-1630 FBC4: n° 1812-CPR-1632 FBC7: n° 1812-CPR-1634	Efectis
--	--	---------

1.5. Components

1. Casing made from galvanized carbon steel.
2. Air duct connection gasket.
3. Intumescent graphite gasket on the outside the casing
4. Intumescent graphite gasket on the inside the casing
5. Damper blade made from refracting material
6. Gasket for sealing between semi-blades
7. Cold smoke air seal gasket
8. Microswitch - on request
9. Thermal fuse fixing spring
10. Fixing blade spring on the casing
11. Thermal fuse locking spring
12. Blade closing spring
13. Temperature controlled closing device (thermal fuse)

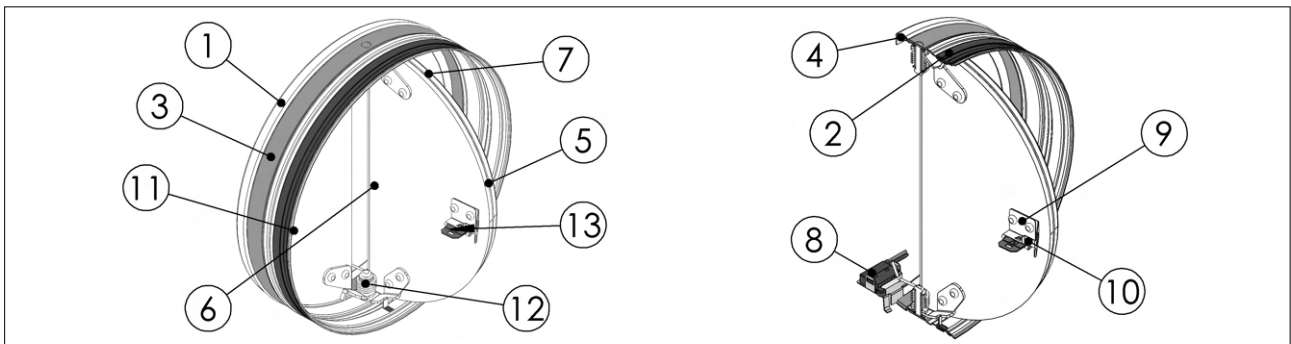

1.6. Available dimensions

∅	mm	100	125	160	200
---	----	-----	-----	-----	-----

1.7. Performances

Performance	Reference standard	Class
Thermal fuse testing	ISO 10294-4	Compliant

1.8. Fire resistance classification according to EN 13501-3-2009

Rigid wall		EI 120 S (300 Pa)	EI 90 S (300 Pa)	EI 60 S (300 Pa)	EI 30 S (300 Pa)
Modello FBC1: foro quadrato, sigillatura in malta o stucco di gesso					
Wall minimum thickness 100 mm Wall minimum density 550 kg/m ³ Mortar or plaster putty sealing ve (i↔o)	W	-	-	FBC1	FBC1
Modello FBC1: foro quadrato, sigillatura in lana di roccia coperta da malta o stucco di gesso					
Wall minimum thickness 100 mm Wall minimum density 550 kg/m ³ Rock wool 40 kg/m ³ and mortar or plaster putty sealing ve (i↔o)	D/W	-	-	FBC1	FBC1
Modello FBC1: foro quadrato, sigillatura in cartongesso e lana di roccia					
Wall minimum thickness 100 mm Wall minimum density 550 kg/m ³ Plasterboard and rock wool 40 kg/m ³ sealing ve (i↔o)	D	-	-	FBC1	FBC1
Modello FBC1, FBC4, FBC7: foro circolare, sigillatura in malta o stucco di gesso					
Wall minimum thickness 100 mm Wall minimum density 550 kg/m ³ Mortar or plaster putty sealing ve (i↔o)	W	FBC7	FBC7 FBC4	FBC7 FBC4 FBC1	FBC7 FBC4 FBC1
Modello FBC4, FBC7: foro quadrato, sigillatura in malta o stucco di gesso					
Wall minimum thickness 100 mm Wall minimum density 550 kg/m ³ Mortar or plaster putty sealing ve (i↔o)	W	FBC7	FBC7 FBC4	FBC4 FBC1	FBC4 FBC1
Modello FBC4, FBC7: foro quadrato, sigillatura in lana di roccia coperta da malta o stucco di gesso					
Wall minimum thickness 100 mm Wall minimum density 550 kg/m ³ Rock wool 40 kg/m ³ and mortar or plaster putty sealing ve (i↔o)	D/W	FBC7	FBC7 FBC4	FBC4 FBC1	FBC4 FBC1
Modello FBC4, FBC7: foro quadrato, sigillatura in cartongesso e lana di roccia					
Wall minimum thickness 100 mm Wall minimum density 550 kg/m ³ Plasterboard and rock wool 40 kg/m ³ sealing ve (i↔o)	D	FBC7	FBC7 FBC4	FBC4 FBC1	FBC4 FBC1
Flexible wall					
		EI 120 S (300 Pa)	EI 90 S (300 Pa)	EI 60 S (300 Pa)	EI 30 S (300 Pa)
Modello FBC1: foro quadrato, sigillatura in malta o stucco di gesso					
Wall minimum thickness 100 mm Wall rock wool density according to the fire resistance class of the wall Mortar or plaster putty sealing ve (i↔o)	W	-	-	FBC1	FBC1
Modello FBC1: foro quadrato, sigillatura in lana di roccia coperta da malta o stucco di gesso					
Wall minimum thickness 100 mm Wall rock wool density according to fire resistance class of the wall Rock wool 40 kg/m ³ and mortar or plaster putty sealing ve (i↔o)	D/W	-	-	FBC1	FBC1
Modello FBC1: foro quadrato, sigillatura in cartongesso e lana di roccia					
Wall minimum thickness 100 mm Wall rock wool density depending on wall fire resistance class Plasterboard and rock wool 40 kg/m ³ sealing ve (i↔o)	D	-	-	FBC1	FBC1
Modello FBC1: foro circolare, sigillatura in malta o stucco di gesso					
Wall minimum thickness 100 mm Wall rock wool density according to the fire resistance class of the wall Mortar or plaster putty sealing ve (i↔o)	W	-	-	FBC1	FBC1
Modello FBC4: foro circolare e quadrato, sigillatura in malta o stucco di gesso					
Wall minimum thickness 100 mm Wall rock wool density according to the fire resistance class of the wall Mortar or plaster putty sealing ve (i↔o)	W	-	FBC4	FBC4 FBC1	FBC4 FBC1
Modello FBC4: foro circolare e quadrato, sigillatura in lana di roccia coperta da malta o stucco di gesso					

Flexible wall		EI 120 S (300 Pa)	EI 90 S (300 Pa)	EI 60 S (300 Pa)	EI 30 S (300 Pa)
Wall minimum thickness 100 mm Wall rock wool density according to fire resistance class of the wall Rock wool 40 kg/m ³ and mortar or plaster putty sealing ve (i↔o)	D/W	-	FBC4	FBC4 FBC1	FBC4 FBC1
Modello FBC4: foro circolare e quadrato, sigillatura in cartongesso e lana di roccia					
Wall minimum thickness 100 mm Wall rock wool density depending on wall fire resistance class Plasterboard and rock wool 40 kg/m ³ sealing ve (i↔o)	D	-	FBC4	FBC4 FBC1	FBC4 FBC1
Modello FBC4, FBC7: foro quadrato, sigillatura in malta o stucco di gesso					
Wall minimum thickness 100 mm Wall rock wool density according to the fire resistance class of the wall Mortar or plaster putty sealing ve (i↔o)	W	FBC7	FBC7 FBC4	FBC7 FBC4 FBC1	FBC7 FBC4 FBC1
Modello FBC4, FBC7: foro quadrato, sigillatura in lana di roccia coperta da malta o stucco di gesso					
Wall minimum thickness 100 mm Wall rock wool density according to fire resistance class of the wall Rock wool 40 kg/m ³ and mortar or plaster putty sealing ve (i↔o)	D/W	FBC7	FBC7 FBC4	FBC7 FBC4 FBC1	FBC7 FBC4 FBC1
Modello FBC4, FBC7: foro quadrato, sigillatura in cartongesso e lana di roccia					
Wall minimum thickness 100 mm Wall rock wool density depending on wall fire resistance class Plasterboard and rock wool 40 kg/m ³ sealing ve (i↔o)	D	FBC7	FBC7 FBC4	FBC7 FBC4 FBC1	FBC7 FBC4 FBC1
Modello FBC4, FBC7: foro circolare, sigillatura in malta o stucco di gesso					
Wall minimum thickness 100 mm Wall rock wool density according to the fire resistance class of the wall Mortar or plaster putty sealing ve (i↔o)	W	FBC7	FBC7 FBC4	FBC7 FBC4 FBC1	FBC7 FBC4 FBC1
Modello FBC4, FBC7: foro circolare, sigillatura in lana di roccia coperta da malta o stucco di gesso					
Wall minimum thickness 100 mm Wall rock wool density according to fire resistance class of the wall Rock wool 40 kg/m ³ and mortar or plaster putty sealing ve (i↔o)	D/W	FBC7	FBC7 FBC4	FBC7 FBC4 FBC1	FBC7 FBC4 FBC1
Modello FBC4, FBC7: foro circolare, sigillatura in cartongesso e lana di roccia					
Wall minimum thickness 100 mm Wall rock wool density depending on wall fire resistance class Plasterboard and rock wool 40 kg/m ³ sealing ve (i↔o)	D	FBC7	FBC7 FBC4	FBC7 FBC4 FBC1	FBC7 FBC4 FBC1
Floor					
		EI 120 S (300 Pa)	EI 90 S (300 Pa)	EI 60 S (300 Pa)	EI 30 S (300 Pa)
Modello FBC1, FBC4, FBC7: foro circolare, sigillatura in malta o stucco di gesso					
Floor minimum thickness 150 mm Floor minimum density 550 kg/m ³ Mortar or plaster putty sealing ho (i↔o)	W	FBC7	FBC7 FBC4	FBC7 FBC4 FBC1	FBC7 FBC4 FBC1
Floor minimum thickness 100 mm Floor minimum density 550 kg/m ³ Mortar or plaster putty sealing ho (i↔o)	W	FBC7	FBC7 FBC4	FBC7 FBC4 FBC1	FBC7 FBC4 FBC1
<p>W Wet method sealing D Dry method sealing ve Vertical installation ho Horizontal installation (i↔o) Origin of fire irrelevant Pa Pascal of depression E Integrity I Thermal insulation S Smoke seal Cert. N° FBC1 1812-CPR-1630, FBC4 1812-CPR-1632, FBC7 1812-CPR-1634</p>					

1.8.1. Fire Batt (Weichschott) sealings

Rigid wall					
		EI 120 S (300 Pa)	EI 90 S (300 Pa)	EI 60 S (300 Pa)	EI 30 S (300 Pa)
Modello FBC1, FBC4, FBC7: foro quadrato, sigillatura Weichschott					
Wall minimum thickness 100 mm					
Wall minimum density 550 kg/m ³					
Rock wool 140 kg/m ³ and endothermic varnish sealing	W	FBC7	FBC7 FBC4	FBC7 FBC4 FBC1	FBC7 FBC4 FBC1
ve (i↔o)					
Flexible wall					
		EI 120 S (300 Pa)	EI 90 S (300 Pa)	EI 60 S (300 Pa)	EI 30 S (300 Pa)
Modello FBC1, FBC4, FBC7: foro quadrato, sigillatura Weichschott					
Wall minimum thickness 100 mm					
Wall rock wool density according to fire resistance class of the wall					
Rock wool 140 kg/m ³ and endothermic varnish sealing	W	FBC7	FBC7 FBC4	FBC7 FBC4 FBC1	FBC7 FBC4 FBC1
ve (i↔o)					
Floor					
		EI 120 S (300 Pa)	EI 90 S (300 Pa)	EI 60 S (300 Pa)	EI 30 S (300 Pa)
Modello FBC1, FBC4, FBC7: foro quadrato, sigillatura Weichschott					
Floor minimum thickness 150 mm					
Floor minimum density 550 kg/m ³					
Rock wool 140 kg/m ³ and endothermic varnish sealing	W	FBC7	FBC7 FBC4	FBC7 FBC4 FBC1	FBC7 FBC4 FBC1
ho (i↔o)					
Floor minimum thickness 100 mm					
Floor minimum density 550 kg/m ³					
Rock wool 140 kg/m ³ and endothermic varnish sealing	W	-	FBC7 FBC4	FBC7 FBC4 FBC1	FBC7 FBC4 FBC1
ho (i↔o)					

W Wet method sealing
D Dry method sealing
ve Vertical installation
ho Horizontal installation
(i↔o) Origin of fire irrelevant
Pa Pascal of depression
E Integrity
I Thermal insulation
S Smoke seal

Cert. N° FBC1 1812-CPR-1630, FBC4 1812-CPR-1632, FBC7 1812-CPR-1634

1.9. Mechanism type

1.9.1. Manual

Blade closing mode

Automatic closing with thermal fuse.

The control mechanism has a thermosensitive element that automatically closes the blade when the temperature in the duct exceeds 70°C.

The damper can be closed manually as per the following instructions.

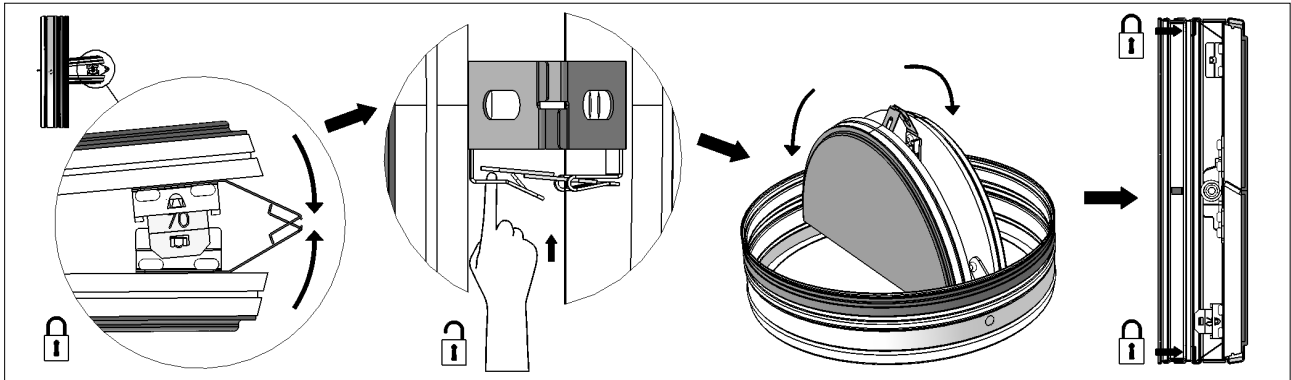

The fire damper is equipped with a spring for closing the blade: pay attention to the hands.

Blade opening mode

Make sure that the damper is open before the ventilation system start-up, otherwise there is a risk of product malfunction.

In case of closed damper as a result of the action of the thermosensitive element, it is possible to manually reopen the damper once the thermosensitive element has been replaced.

The fire damper can be opened manually as per the following instructions.

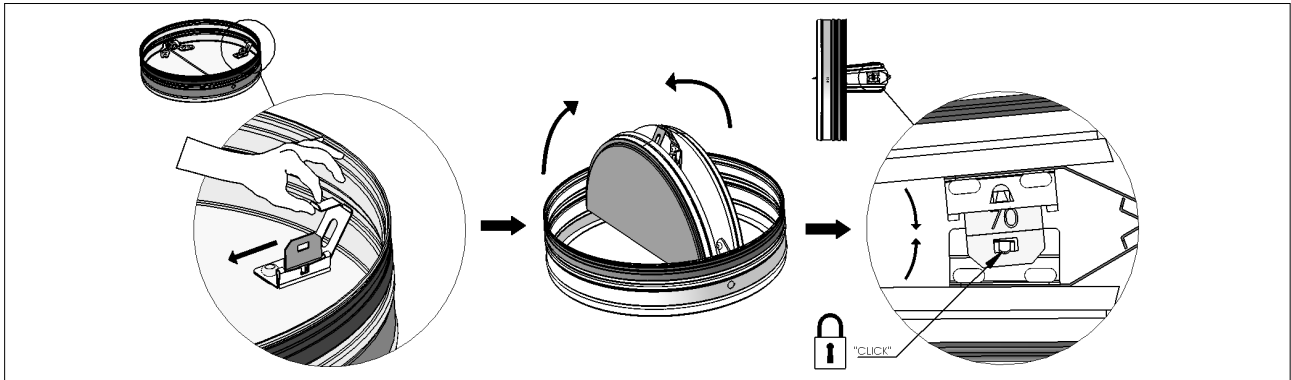

The fire damper is equipped with a spring for closing the blade: pay attention to the hands.

Position indication microswitch

On request, the fire damper can be supplied with position microswitch (S1 optional) that signal the closed position of the blade. Refer to the section Electrical connections [p. 39](#) for more details.

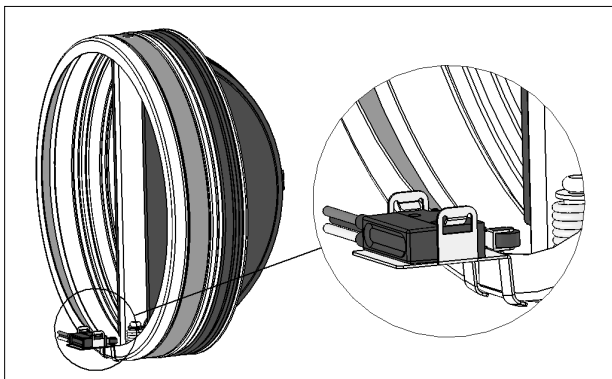

Temperature calibration of thermosensitive element for automatic damper closing

70 °C±7 °C

1.9.2. Closing by remote control

Not available

1.9.3. Motorized version

Not available

2. TECHNICAL DATA

The sizes shown are in mm.

2.1. Dimension

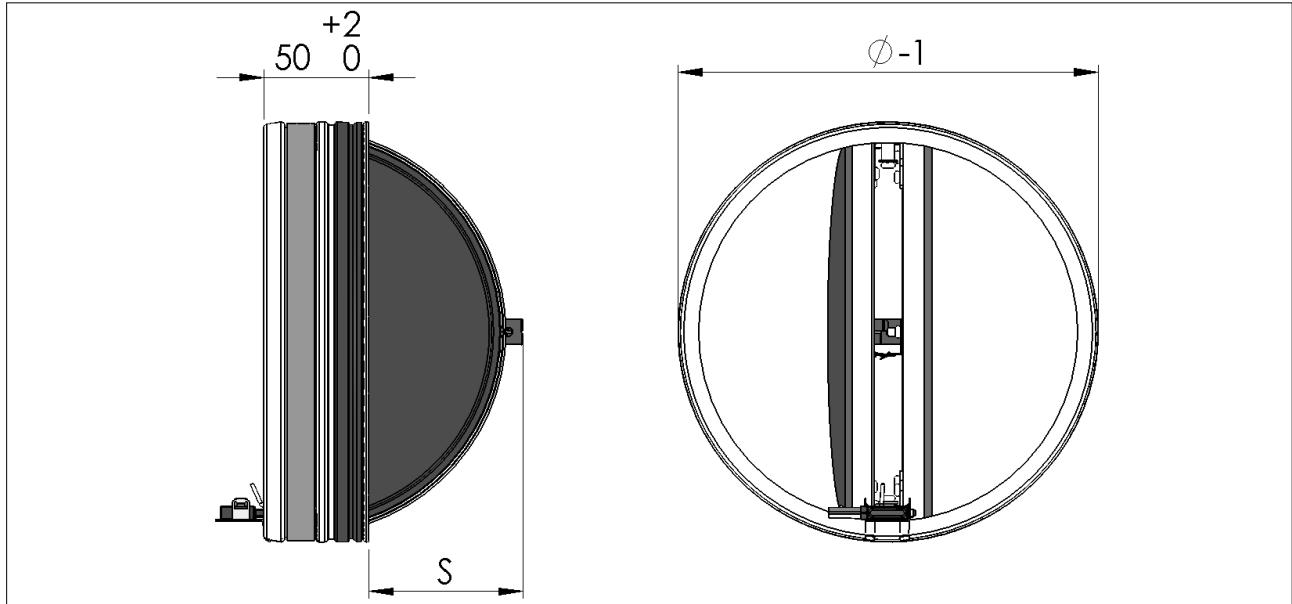

Ø	mm	100	125	160	200
S blade exposition	mm	21	34	51	72

2.2. Weights

Ø	mm	100	125	160	200
Weight	kg	0,3	0,4	0,5	0,9

3. INSTALLATION

The sizes shown are in mm.

It is recommended to perform a functional test before Installation to exclude possible damage during transport.

The fire dampers FBC must be accessible for maintenance and inspections.

3.1. Intended use

The MP3 fire dampers are "Devices for use in heating, ventilation and air conditioning (HVAC) systems at fire boundaries to maintain compartmentation and protect means of escape in case of fire" according to the 3.1 paragraph of EN 15650:2010 standard.

It is compulsory to install the fire damper according to the instructions indicated in the technical data sheet and manual to maintain the declared performances and, in particular, the fire classes.

The double test (with the mechanism inside and outside the fire area) demonstrated that there is no preferred direction for the position of the damper, both in relation to air flow and the side with the higher probability of exposure to fire, as indicated in standard EN1366-2:2015 (paragraph 6.2).

Use permitted in any civil and industrial building.

3.2. Not allowed uses

- Use with installations different to those described in the technical data sheet and manual;
- use as smoke control damper;
- use as shut off damper;
- use in explosive environments;
- use on board of ships;
- use in cooker extraction hoods;
- use in pneumatic conveying systems of dust or corn;
- use in ventilation systems within locations subject to chemical contamination;
- use in non inspectable environments;
- installation in fire resistant false ceilings crossings;
- use in ventilation ducts where condensation can occur.

3.3. Blade rotation axis positioning

The fire damper can be installed with the blade axis positioned vertically or horizontally or tilted at any angle.

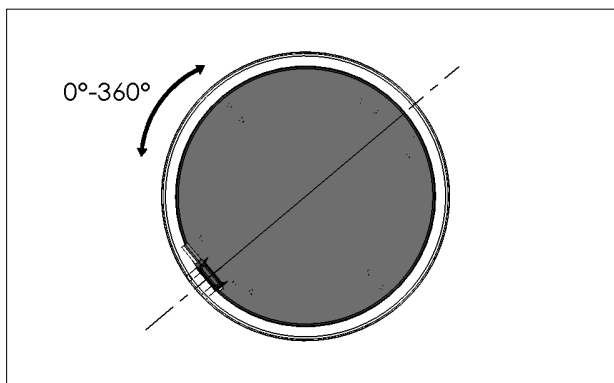

3.4. Installation of flexible connectors in order to balance out the ventilation ducts expansion

ATTENTION: the following indications must be considered binding only if legislation or local regulation where the fire dampers are installed require the use of flexible connectors.

Flexible connectors compensate any duct thermal expansion and wall bending in case of fire.

Flexible connectors are used to limit fire damper stresses due to external forces in case of fire and to preserve fire resistance class.

In general it is always appropriate the use of flexible connectors for the followings installations:

- light walls;
- Plasterboard and rock wool or Fire Batt (Weichschott) sealing;
- Applique fixing system.

Flexible connector must be normal flammability and in case of fire the grounding bonding should disconnect to guarantee the complete separation between fire damper and connected air duct.

When flexible connectors made of conductive material (e.g. aluminum) are used, no additional grounding bonding is required.

Despite flexible connector installation, the fire damper must be installed in the construction support so that its weight does not affect damper's installation position both during normal operation and in case of fire.

It is recommended not to compress flexible connectors in the installation phase.

Flexible connector must be at least 100mm long and in order that possible duct thermal expansions are balanced.

Take care that the flexible connector does not interfere with opening / closing movement of the blade.

Refer to the section Technical data [p. 10](#) for blade exposition values.

3.5. Minimum distances

In accordance with Articles 7 and 13 of EN 1366-2 respect the minimum distances indicated below.

Minimum distances

- 1. Vertical lateral wall
- 2. Floor

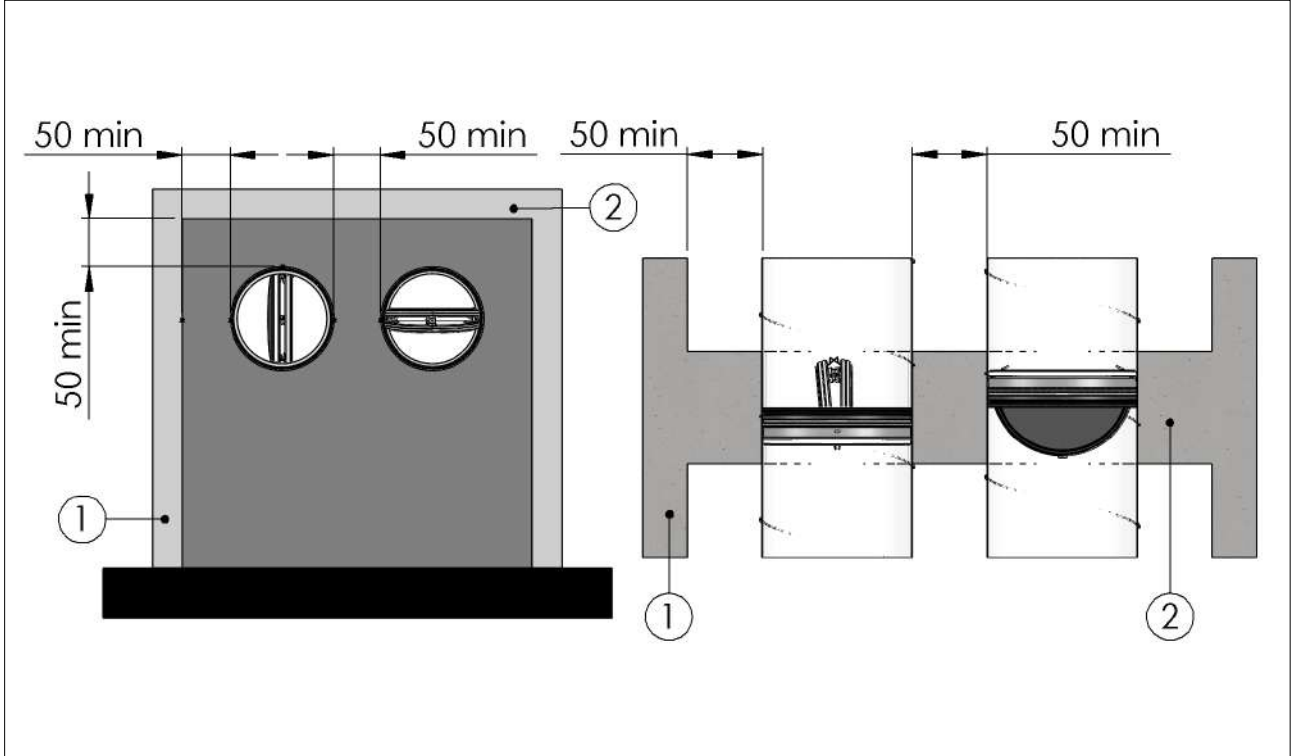

3.6. Construction supports characteristics

The European standard for fire dampers foresees a precise correlation between the wall/floor characteristics and the fire resistance class obtained, as well as the correlation between wall/floor used for the test and wall/floor used for the actual installation.

The test results obtained on a type of wall/floor are valid also for walls/floor of the same type but with greater thickness and/or density than those used in the test.

For plasterboard walls, the test results are also valid for walls with a greater number of plasterboard layers on each side. As a result, the indicated thickness and density characteristics are to be considered as minimum values.

The wall/floor in which the fire dampers are installed must be fire class certified according to the standards foreseen for the structure.

3.6.1. Rigid walls

Can be made with aerated concrete blocks, poured concrete, concrete panels, perforated cell elements in concrete or brick in accordance with the following characteristics:

- minimum thickness 100 mm;
- minimum density 550 kg/m³.

For walls built with perforated elements, it is also recommended that the area of the opening be made from full elements (for example aerated concrete blocks) to guarantee the correct adhesion of the mortar.

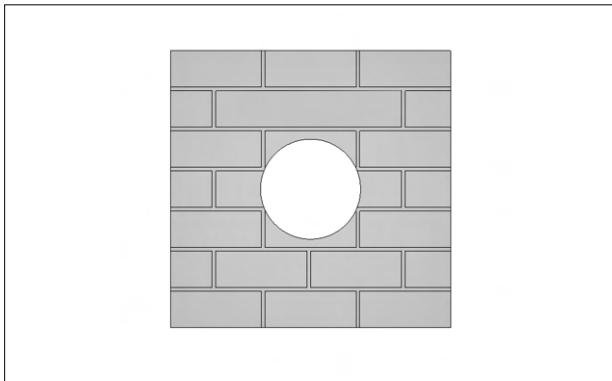

3.6.2. Light plasterboard vertical walls

During testing, light plasterboard walls have been used with the following characteristics:

- U-shaped horizontal metal frame (50 mm) and C-shaped vertical frame (49 mm) made from 0,6 mm thick sheet metal;
- vertical profiles placed with a maximum spacing of 1000 mm;
- Filling made of rock wool;
- Each side is made from two plasterboard layers 12,5 mm thick, unalined to avoid alignment between the joints of the layer above and below.

The following indications are given for the installation walls:

- metal profiles minimum width: 49 mm;
- metal profiles minimum thickness: 0,6 mm;
- vertical profiles placed with a maximum spacing of 1000 mm between each other;

- vertical profile fixing with selfthreading screws or by clinching to the bottom horizontal profile and insertion in the top horizontal profile;
- profiles fixed using self-threading screws or by clinching on every intersection.
- installation of a frame around the damper with base and height where shown in the installation instructions;
- Filling made of rock wool;
- each side is made from two plasterboard layers 12,5 mm minimum thick, unalined to avoid alignment between the joints of the layer above and below.
- the front plasterboards layers are fixed using long enough screws to pass through the lower plasterboard and attach to the steel profile underneath.

1. Plasterboard thickness 12,5 mm
2. Rock wool
3. Horizontal U-shaped profile
4. Vertical C-shaped profile
5. Self-drilling screw Ø 3,5 X 25 mm
6. Self-drilling screw Ø 3,5 X 35 mm

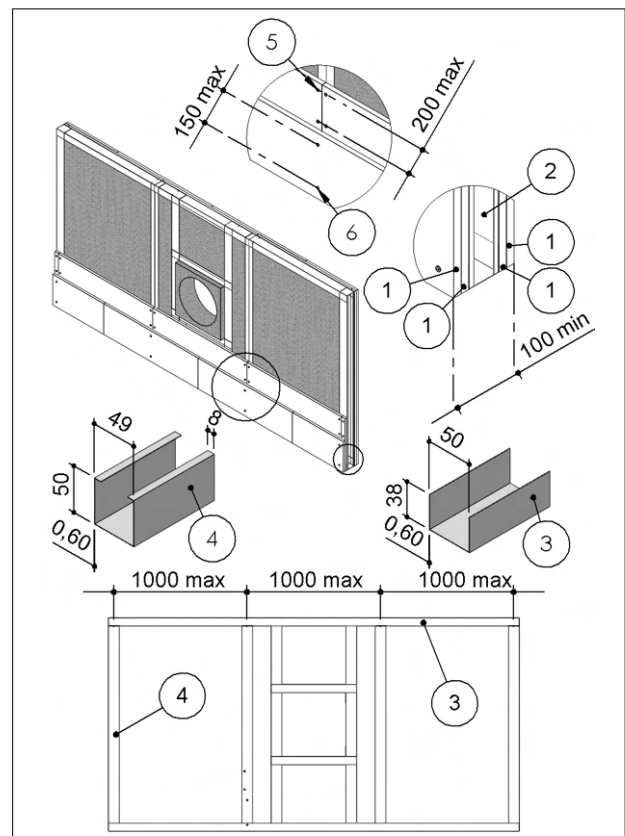

3.6.3. Concrete floors

Concrete floors can be built during installation or with pre-formed slabs with interlocking shaped edges according to the following characteristics:

- minimum thickness 100 or 150 mm according to the type and resistance class required;
- minimum density 550 kg/m³.

3.7. Installations within vertical rigid wall

Refer to the section Construction supports characteristics [p.13](#) for further information.

Comply with the minimum distances indicated on section Minimum distances [p.12](#).

Before and after installation please perform a functional test. Refer to section Mechanism type for further information [p.8](#).

3.7.1. Wall opening

A opening must be provided in the wall as indicated in the drawing.

3.7.2. Damper positioning

Install the fire damper in the ventilation duct as shown in the drawing.

Close the blade before installing the fire damper.

3.7.3. Filling

Fill the space between ventilation duct and wall as indicated in the drawing. Sealing with concrete is not allowed.

3.7.4. Insulation

Apply the adhesive gaskets supplied with the damper at a distance of 15 mm from the sealing.

When the fire damper is installed in shafts exit (technical compartments where continuous presence or transit of people is not foreseen) it is not necessary to apply the adhesive gasket supplied with the fire damper on the duct side inside the shaft.

The shafts walls shall have fire resistance equal or higher to the one of the fire damper.

Model FBC1: square hole, mortar or plaster putty sealing

- | | |
|--|---|
| <ol style="list-style-type: none"> 1. Mortar or plaster putty 2. Adhesive gasket (supplied with the damper). Refer to the section Insulation if necessary 3. Ventilation duct | <ol style="list-style-type: none"> 4. Fire damper 5. Vertical rigid wall, minimum density 550 kg/m³ <p>D from nominal diameter min + 50 to nominal diameter max + 70</p> |
|--|---|

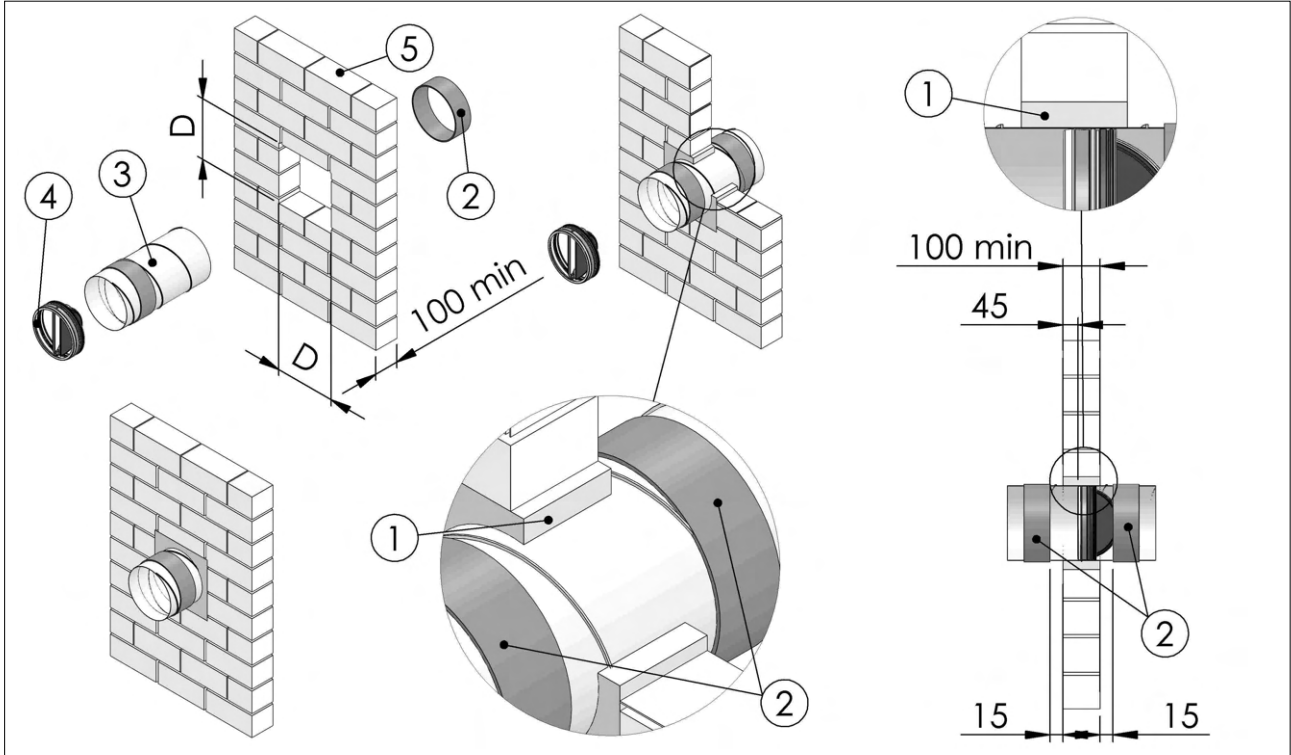

Model FBC1: square hole, mortar or plaster putty covered rock wool sealing

- | | |
|-----------------------------------|---|
| 1. Rock wool 40 kg/m ³ | 5. Vertical rigid wall, minimum density 550 kg/m ³ |
| 2. Mortar or plaster putty | 6. Adhesive gasket (supplied with the damper). Refer to the section |
| 3. Ventilation duct | Insulation if necessary |
| 4. Fire damper | D from nominal diameter min + 50 to nominal diameter max + 70 |

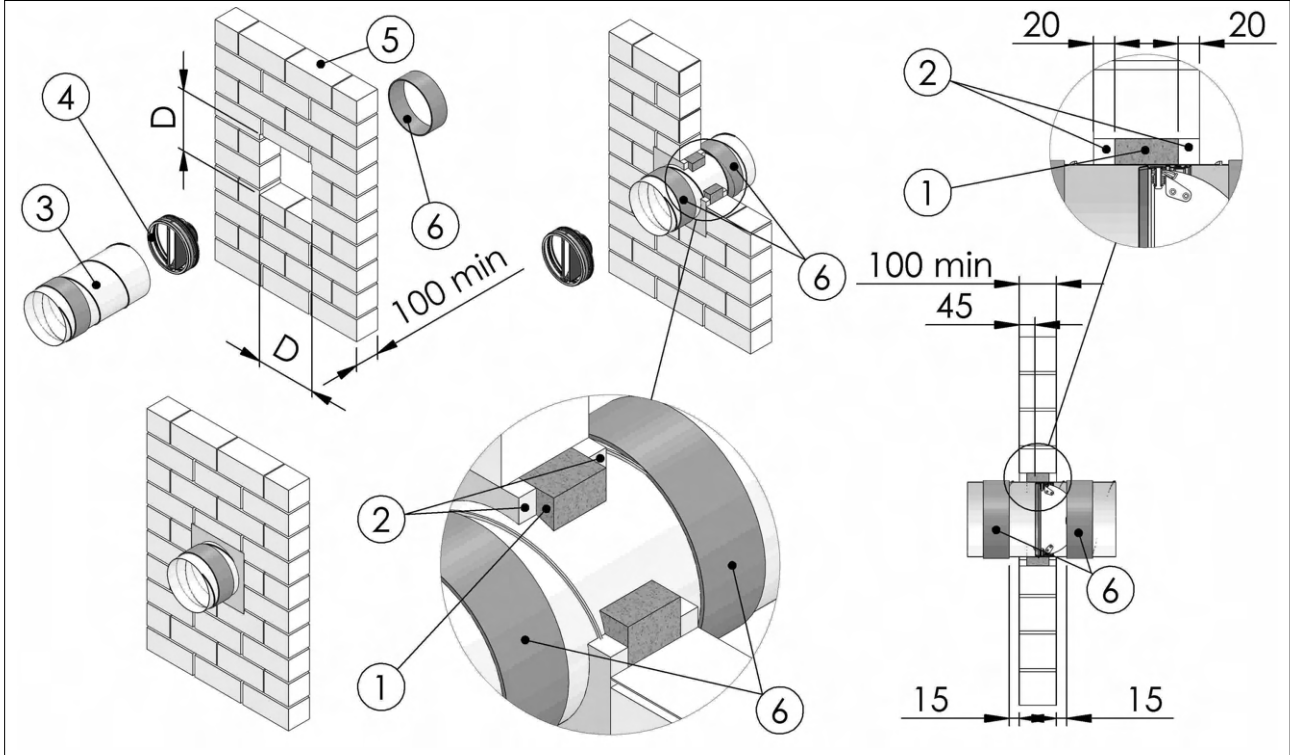

Model FBC1: square hole, plasterboard and rock wool sealing

- | | |
|--|--|
| <ol style="list-style-type: none"> 1. Plasterboard arch infill, thickness 12,5 mm 2. Rock wool, 100 kg/m³ or mortar or plaster putty 3. Ventilation duct 4. Fire damper 5. Self-drilling screw $\varnothing 3,5 \times 45$ mm | <ol style="list-style-type: none"> 6. Adhesive gasket (supplied with the damper). Refer to the section Insulation if necessary 7. Vertical rigid wall, minimum density 550 kg/m³ <p>D from nominal diameter min + 50 to nominal diameter max + 70</p> |
|--|--|

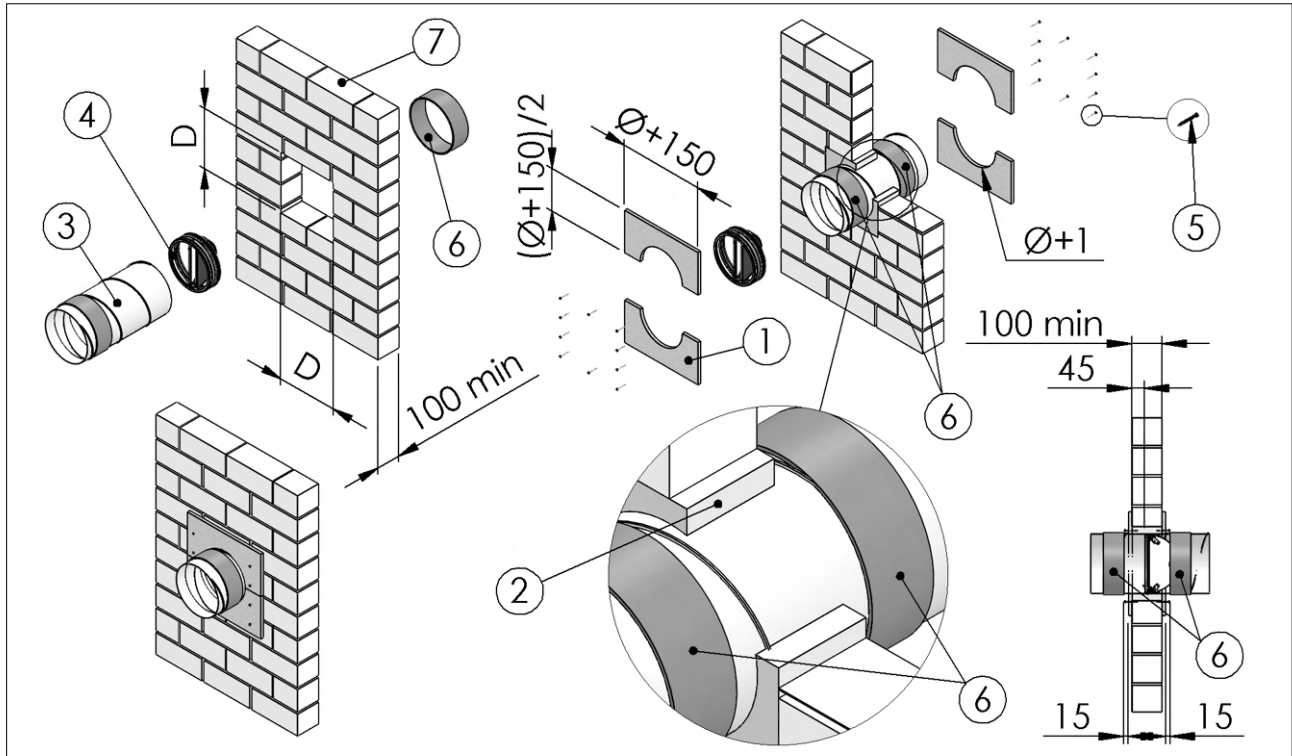

Model FBC1 - FBC4 - FBC7: circular hole, mortar or plaster putty sealing

- | | |
|--|---|
| 1. Ventilation duct | 4. Fire damper |
| 2. Mortar or plaster putty | 5. Vertical rigid wall, minimum density 550 kg/m ³ |
| 3. Adhesive gasket (supplied with the damper). Refer to the section
Insulation if necessary | D from nominal diameter min + 50 to nominal diameter max + 70 |

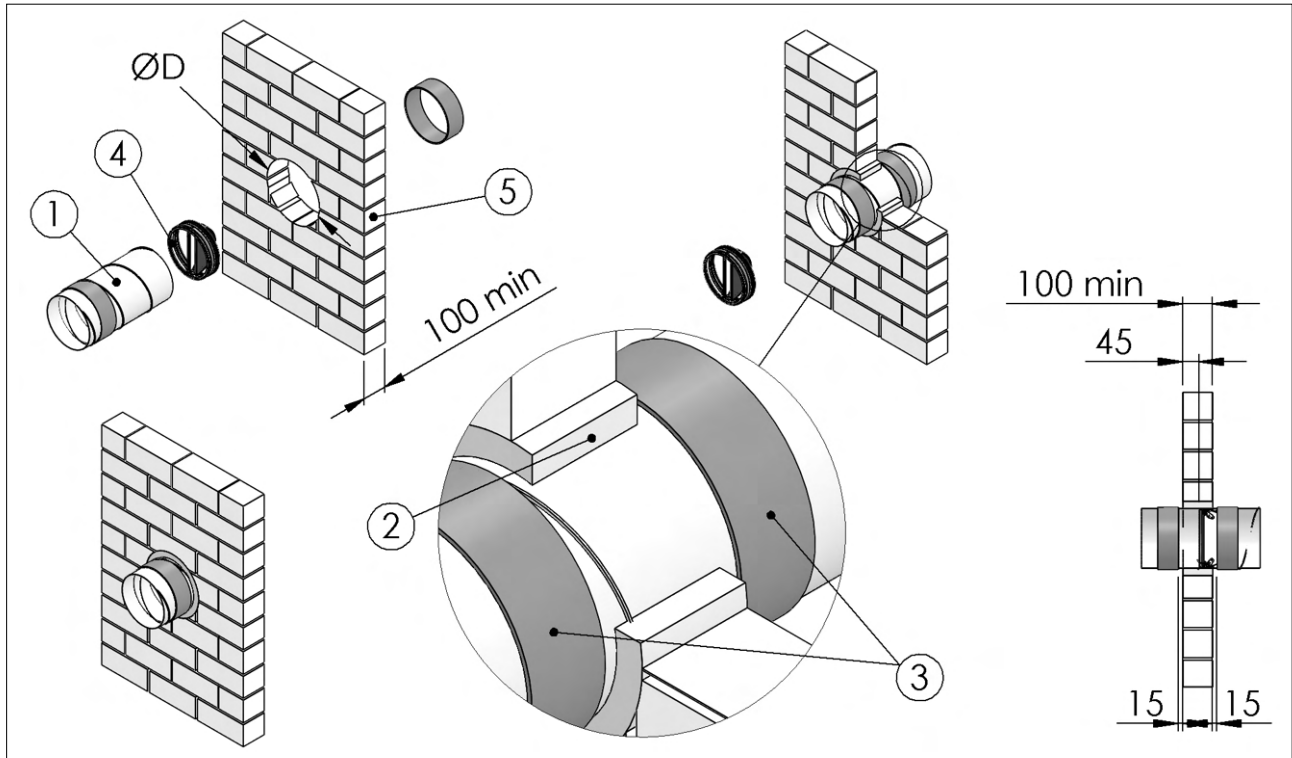

Model FBC4 - FBC7: square hole, mortar or plaster putty sealing

- | | |
|--|--|
| 1. Mortar or plaster putty | 4. Fire damper |
| 2. Adhesive gasket (supplied with the damper). Refer to the section
Insulation if necessary | 5. Vertical rigid wall, minimum density 550 kg/m ³
D from nominal diameter min + 50 to nominal diameter max + 70 |
| 3. Ventilation duct | |

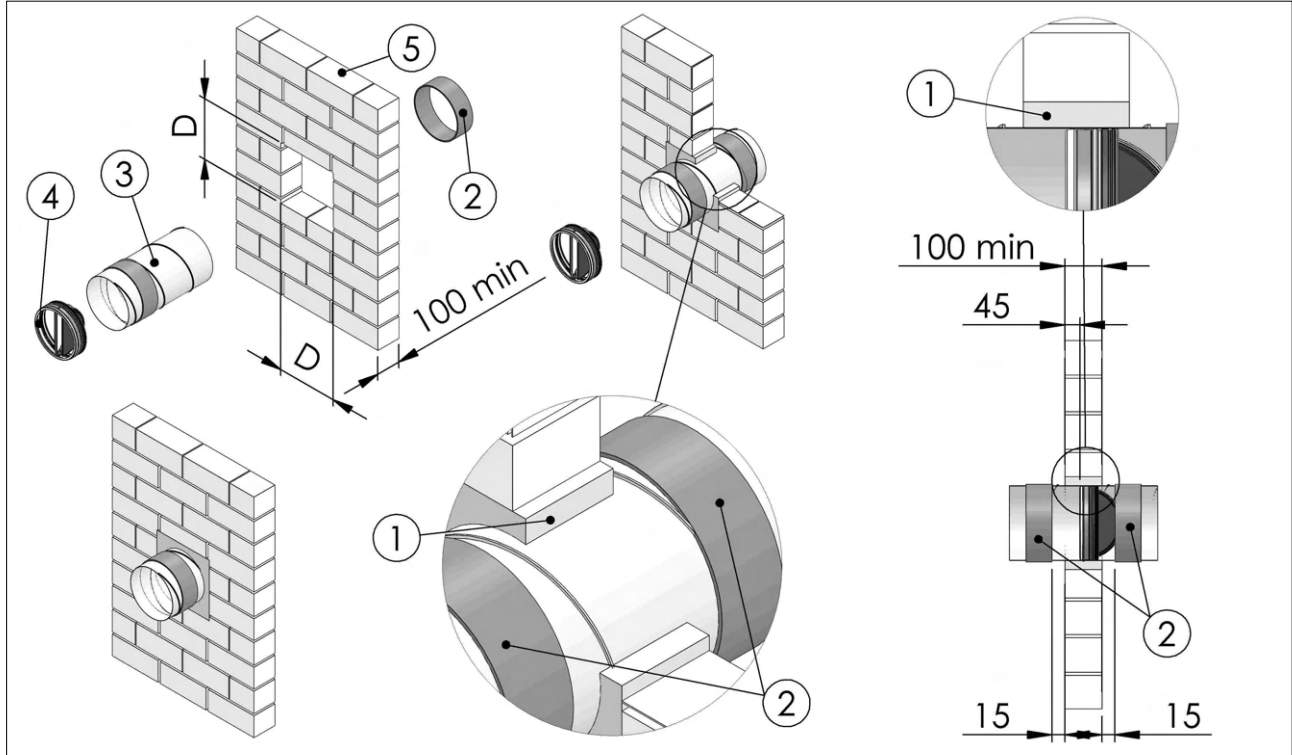

Model FBC4 - FBC7: square hole, mortar or plaster putty covered rock wool sealing

- | | |
|-----------------------------------|---|
| 1. Rock wool 40 kg/m ³ | 5. Vertical rigid wall, minimum density 550 kg/m ³ |
| 2. Mortar or plaster putty | 6. Adhesive gasket (supplied with the damper). Refer to the section |
| 3. Ventilation duct | Insulation if necessary |
| 4. Fire damper | D from nominal diameter min + 50 to nominal diameter max + 70 |

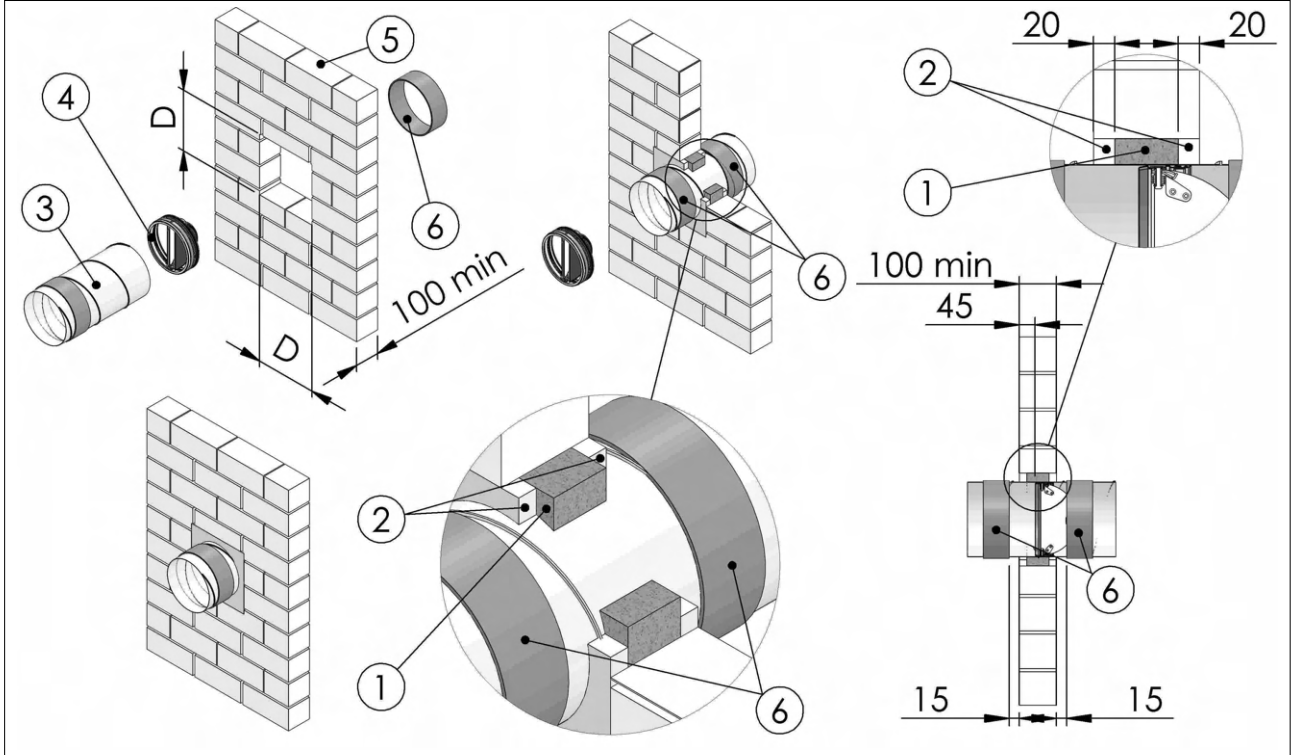

Model FBC4 - FBC7: square hole, plasterboard and rock wool sealing

- | | |
|---|---|
| 1. Fire damper | 5. Plasterboard arch infill, thickness 12,5 mm |
| 2. Rock wool, 100 kg/m ³ or mortar or plaster putty | 6. Ventilation duct |
| 3. Self-drilling screw Ø 3,5 X 45 mm | 7. Vertical rigid wall, minimum density 550 kg/m ³ |
| 4. Adhesive gasket (supplied with the damper). Refer to the section Insulation if necessary | D from nominal diameter min + 50 to nominal diameter max + 70 |

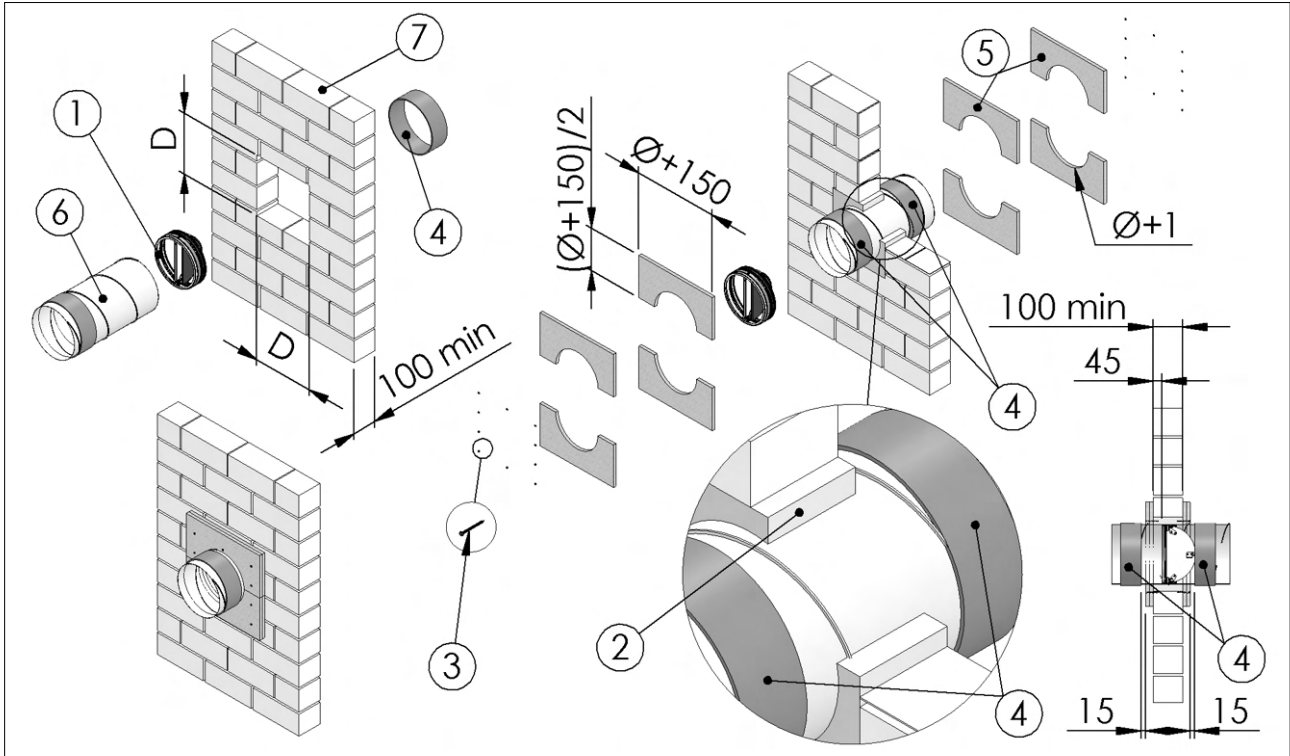

3.8. Installations within vertical light wall (plasterboard)

Refer to the section Construction supports characteristics [p.13](#) for further information.

Comply with the minimum distances indicated on section Minimum distances [p.12](#).

Before and after installation please perform a functional test. Refer to section Mechanism type for further information [p.8](#).

3.8.1. Wall opening

A opening must be provided in the wall as indicated in the drawing.

3.8.2. Damper positioning

Install the fire damper in the ventilation duct as shown in the drawing.

Close the blade before installing the fire damper.

3.8.3. Filling

Fill the space between ventilation duct and wall as indicated in the drawing. Sealing with concrete is not allowed.

3.8.4. Insulation

Apply the adhesive gaskets supplied with the damper at a distance of 15 mm from the sealing.

When the fire damper is installed in shafts exit (technical compartments where continuous presence or transit of people is not foreseen) it is not necessary to apply the adhesive gasket supplied with the fire damper on the duct side inside the shaft.

The shafts walls shall have fire resistance equal or higher to the one of the fire damper.

Model FBC1: square hole, mortar or plaster putty sealing

- | | |
|--|---|
| 1. Wall rock wool density according to fire resistance class of the wall | 6. Metal frame |
| 2. Mortar or plaster putty | 7. Adhesive gasket (supplied with the damper). Refer to the section |
| 3. Type A (EN 520) plasterboard thickness 12,5 mm | Insulation if necessary |
| 4. Fire damper | D from nominal diameter min + 50 to nominal diameter max + 70 |
| 5. Ventilation duct | |

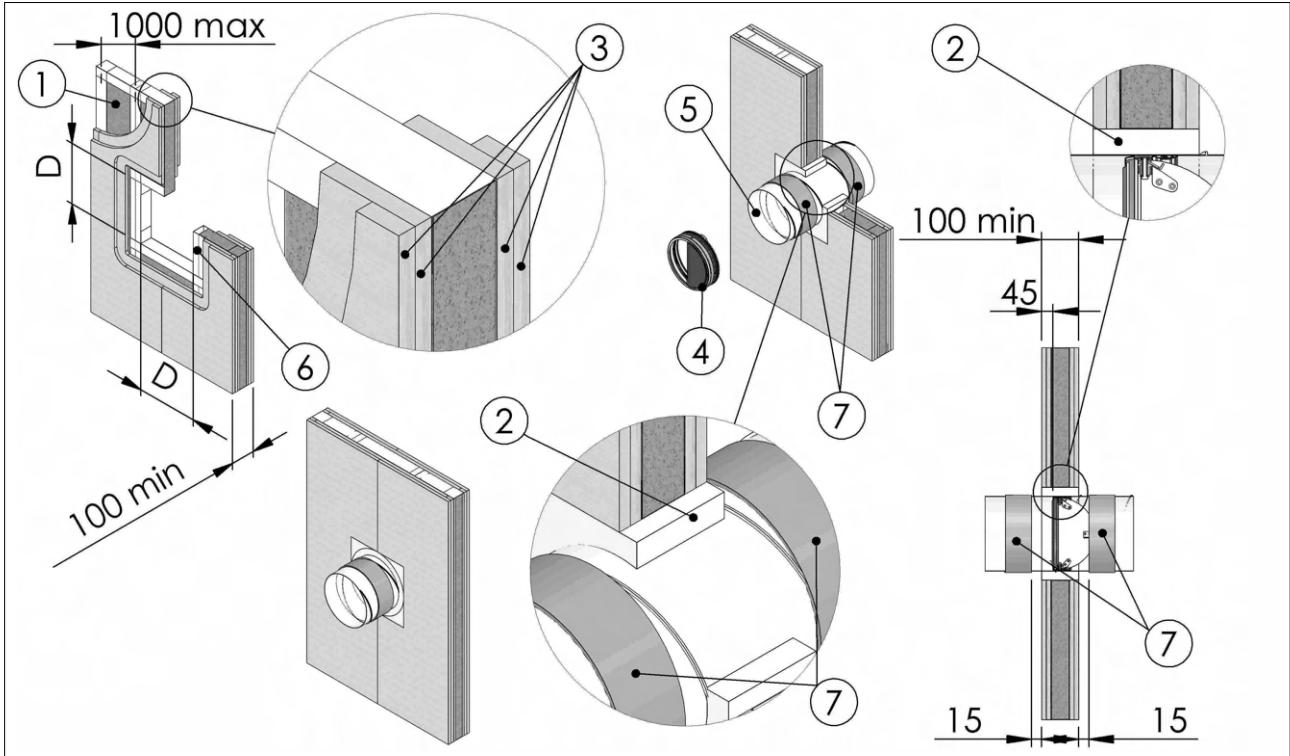

Model FBC1: square hole, mortar or plaster putty covered rock wool sealing

- | | |
|--|---|
| 1. Wall rock wool density according to fire resistance class of the wall | 6. Metal frame |
| 2. Mortar or plaster putty | 7. Adhesive gasket (supplied with the damper). Refer to the section |
| 3. Type A (EN 520) plasterboard thickness 12,5 mm | Insulation if necessary |
| 4. Fire damper | 8. Rock wool 40 kg/m ³ |
| 5. Ventilation duct | D from nominal diameter min + 50 to nominal diameter max + 70 |

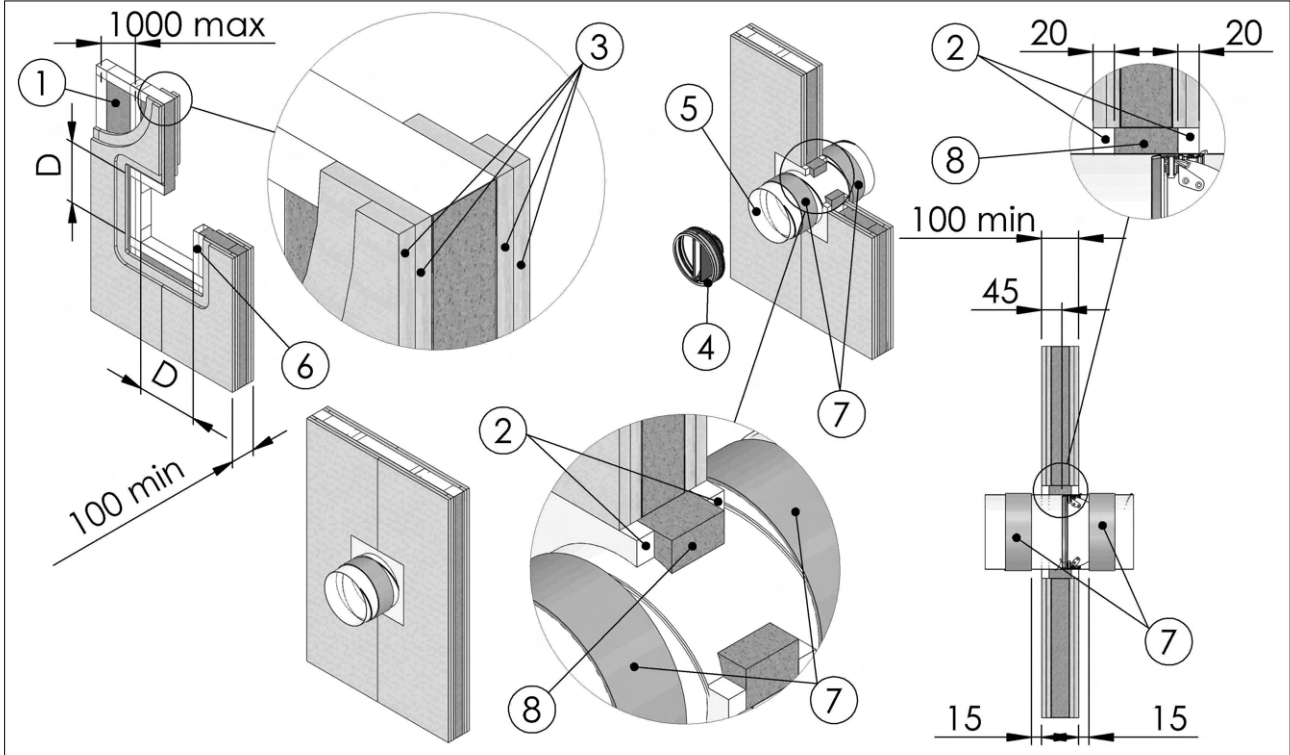

Model FBC1: square hole, plasterboard and rock wool sealing

- | | |
|--|---|
| 1. Wall rock wool density according to fire resistance class of the wall | 6. Metal frame |
| 2. Plasterboard arch infill, thickness 12,5 mm | 7. Adhesive gasket (supplied with the damper). Refer to the section Insulation if necessary |
| 3. Type A (EN 520) plasterboard thickness 12,5 mm | 8. Fire damper |
| 4. Sealing: rock wool 40 kg/m ³ or mortar or plaster putty | 9. Ventilation duct |
| 5. Self-drilling screw \varnothing 3,5 X 45 mm | D from nominal diameter min + 50 to nominal diameter max + 70 |

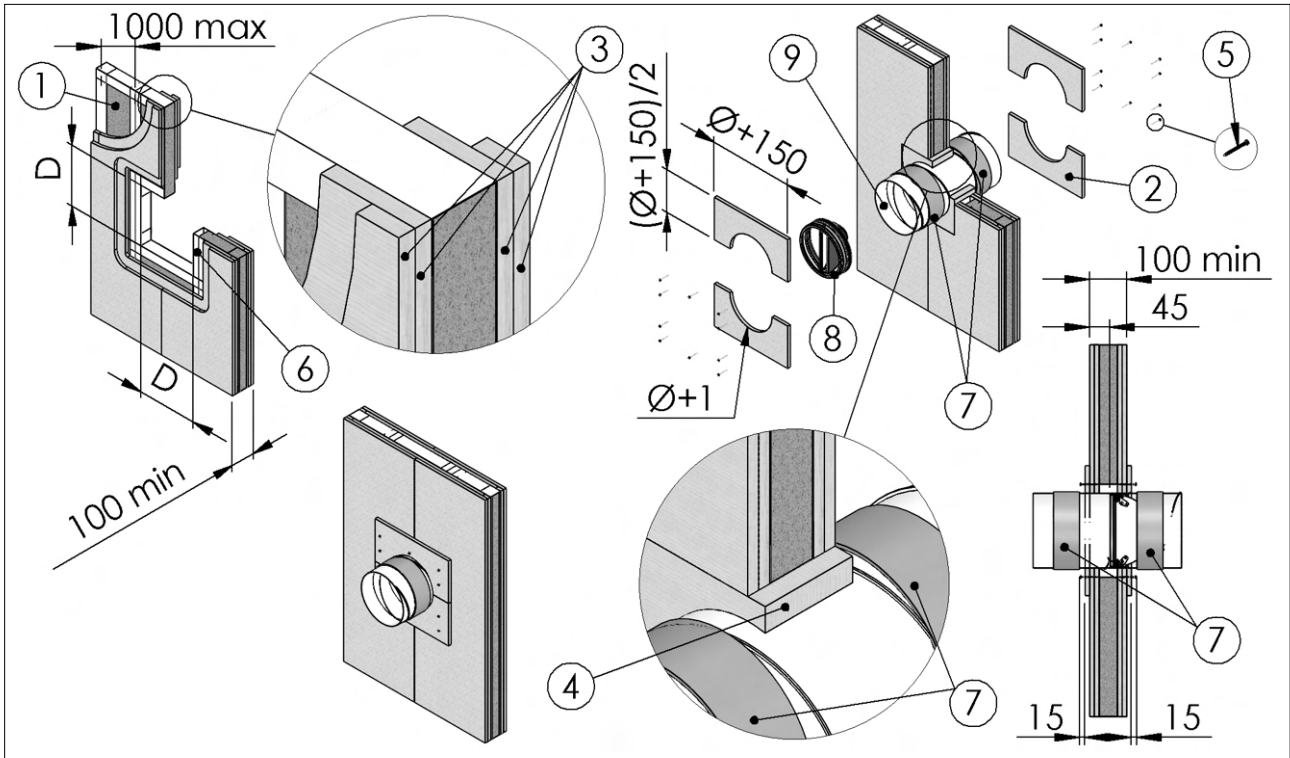

Model FBC1: circular hole, mortar or plaster putty sealing

- | | |
|--|---|
| 1. Wall rock wool density according to fire resistance class of the wall | 5. Adhesive gasket (supplied with the damper). Refer to the section Insulation if necessary |
| 2. Metal frame | 6. Fire damper |
| 3. Type A (EN 520) plasterboard thickness 12,5 mm | 7. Ventilation duct |
| 4. Mortar or plaster putty | D from nominal diameter min + 50 to nominal diameter max + 70 |

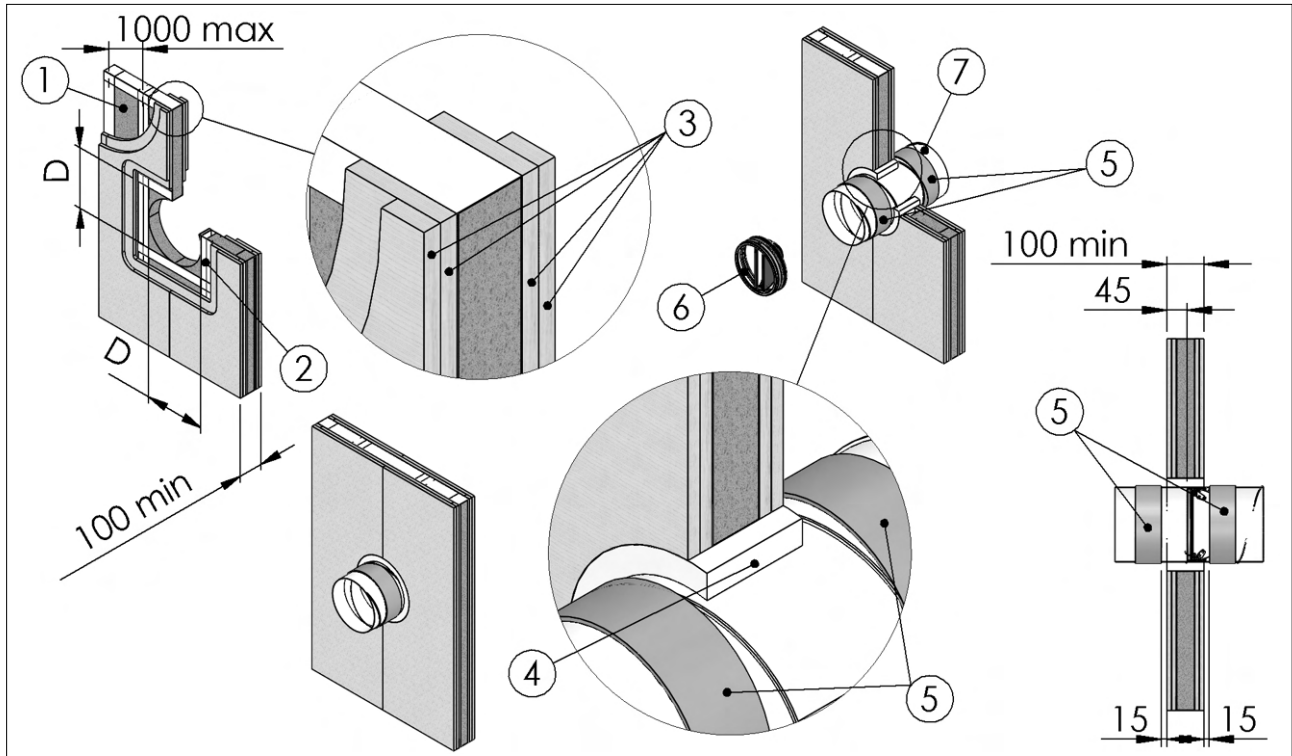

Model FBC4: circular and square hole, mortar or plaster putty sealing

- | | |
|--|---|
| 1. Wall rock wool density according to fire resistance class of the wall | 5. Adhesive gasket (supplied with the damper). Refer to the section Insulation if necessary |
| 2. PROMASTOP E PASTE or HILTI CFS-S ACR type sealant | 6. Metal frame |
| 3. Plasterboard, thickness 12,5 mm F type (EN 520) | 7. Ventilation duct |
| 4. Mortar or plaster putty | 8. Fire damper |
| | D from nominal diameter min + 50 to nominal diameter max + 70 |

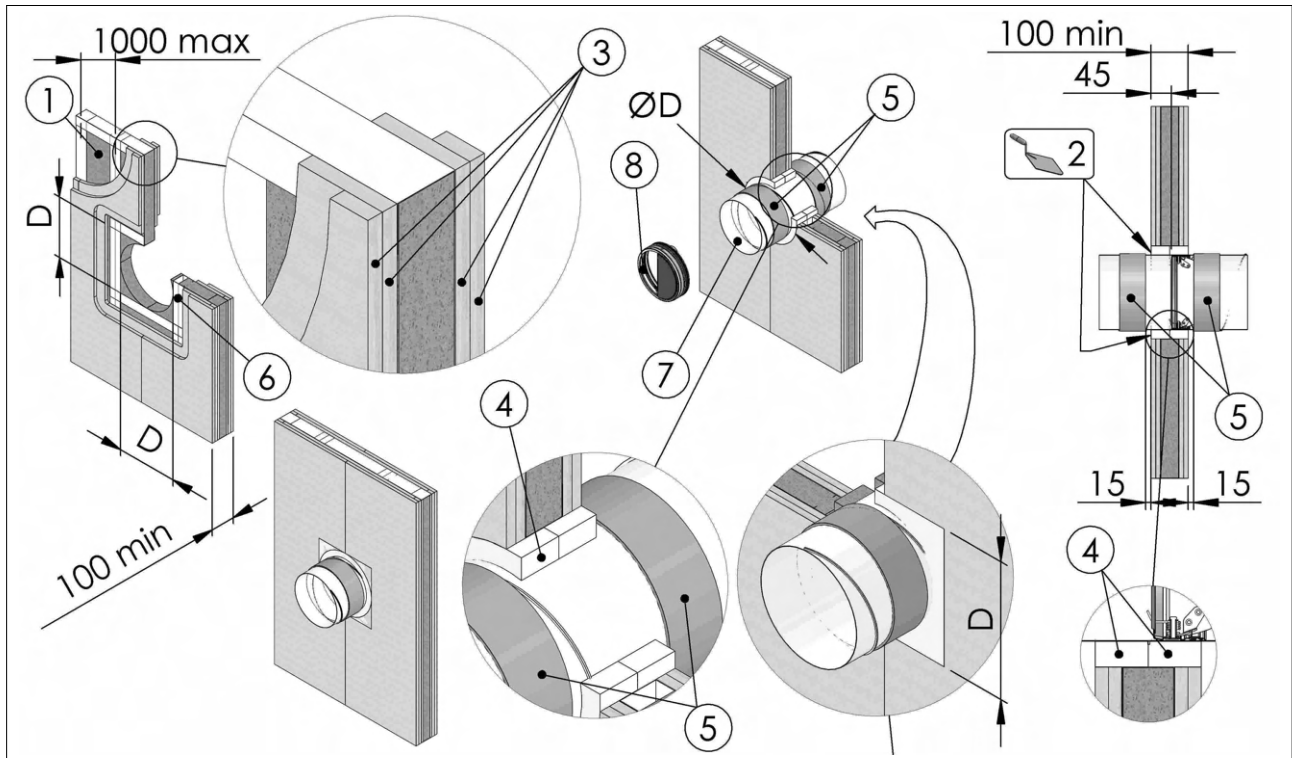

Model FBC4: circular and square hole, mortar or plaster putty covered rock wool sealing

- | | |
|---|---|
| 1. Wall rock wool density according to fire resistance class of the wall | 6. Metal frame |
| 2. PROMASTOP E PASTE or HILTI CFS-S ACR type sealant | 7. Ventilation duct |
| 3. Plasterboard, thickness 12,5 mm F type (EN 520) | 8. Fire damper |
| 4. Mortar or plaster putty | 9. Rock wool, 40 kg/m ³ |
| 5. Adhesive gasket (supplied with the damper). Refer to the section Insulation if necessary | D from nominal diameter min + 50 to nominal diameter max + 70 |

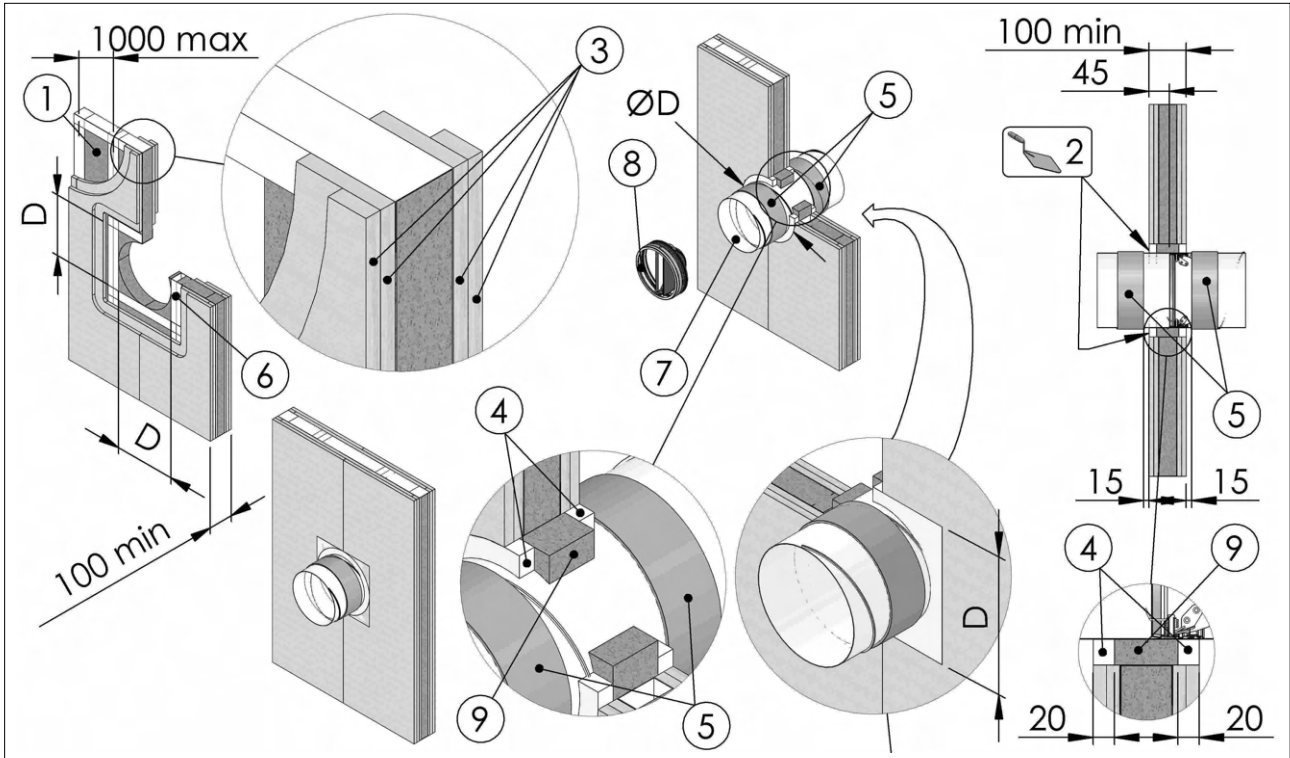

Model FBC4: circular and square hole, plasterboard and rock wool sealing

- | | |
|---|---|
| 1. Wall rock wool density according to fire resistance class of the wall | 6. Metal frame |
| 2. PROMASTOP E PASTE or HILTI CFS-S ACR type sealant | 7. Ventilation duct |
| 3. Plasterboard, thickness 12,5 mm F type (EN 520) | 8. Fire damper |
| 4. Rock wool, 40 kg/m ³ or mortar or plaster putty | 9. Plasterboard arch infill, thickness 12,5 mm |
| 5. Adhesive gasket (supplied with the damper). Refer to the section Insulation if necessary | 10. Self-drilling screw Ø 3,5 X 45 mm |
| | D from nominal diameter min + 50 to nominal diameter max + 70 |

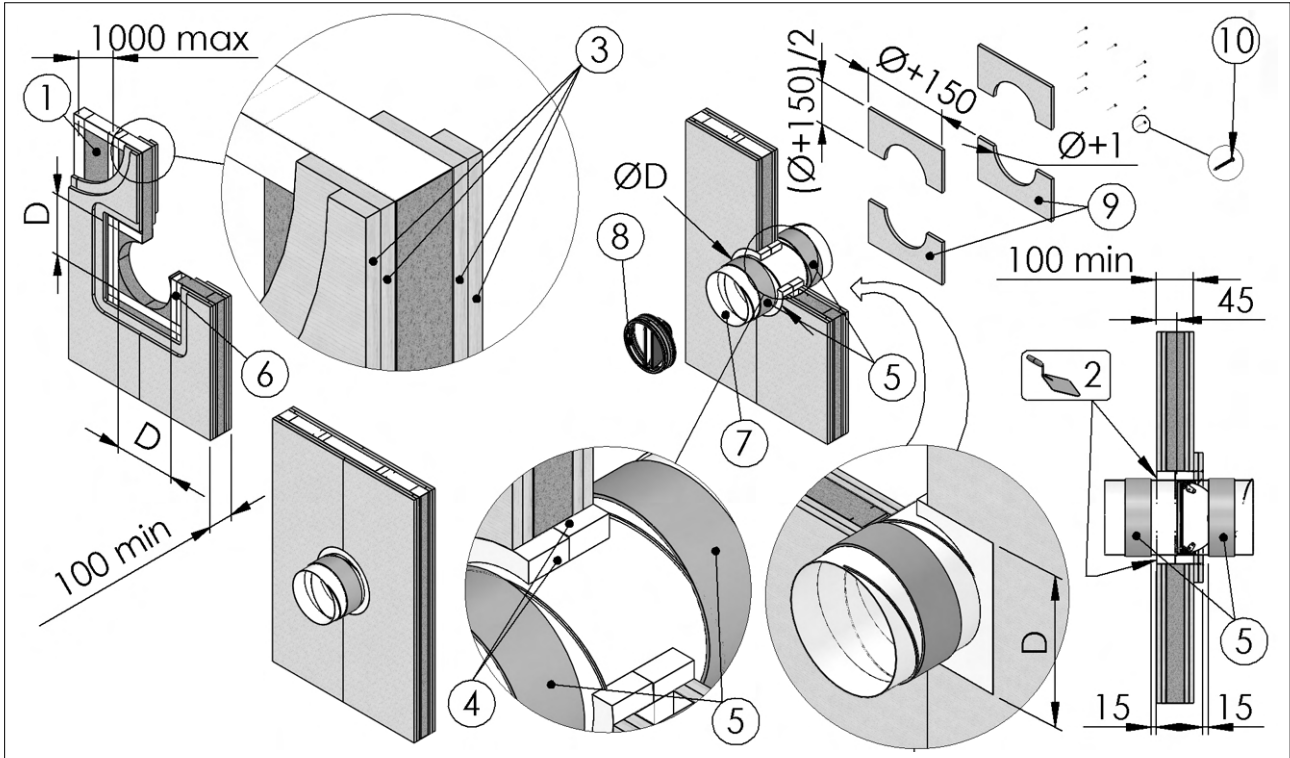

Model FBC4 - FBC7: square hole, mortar or plaster putty sealing

- | | |
|--|---|
| 1. Wall rock wool density according to fire resistance class of the wall | 5. Adhesive gasket (supplied with the damper). Refer to the section Insulation if necessary |
| 2. Metal frame | 6. Ventilation duct |
| 3. Plasterboard, thickness 12,5 mm F type (EN 520) | 7. Fire damper |
| 4. Mortar or plaster putty | D from nominal diameter min + 50 to nominal diameter max + 70 |

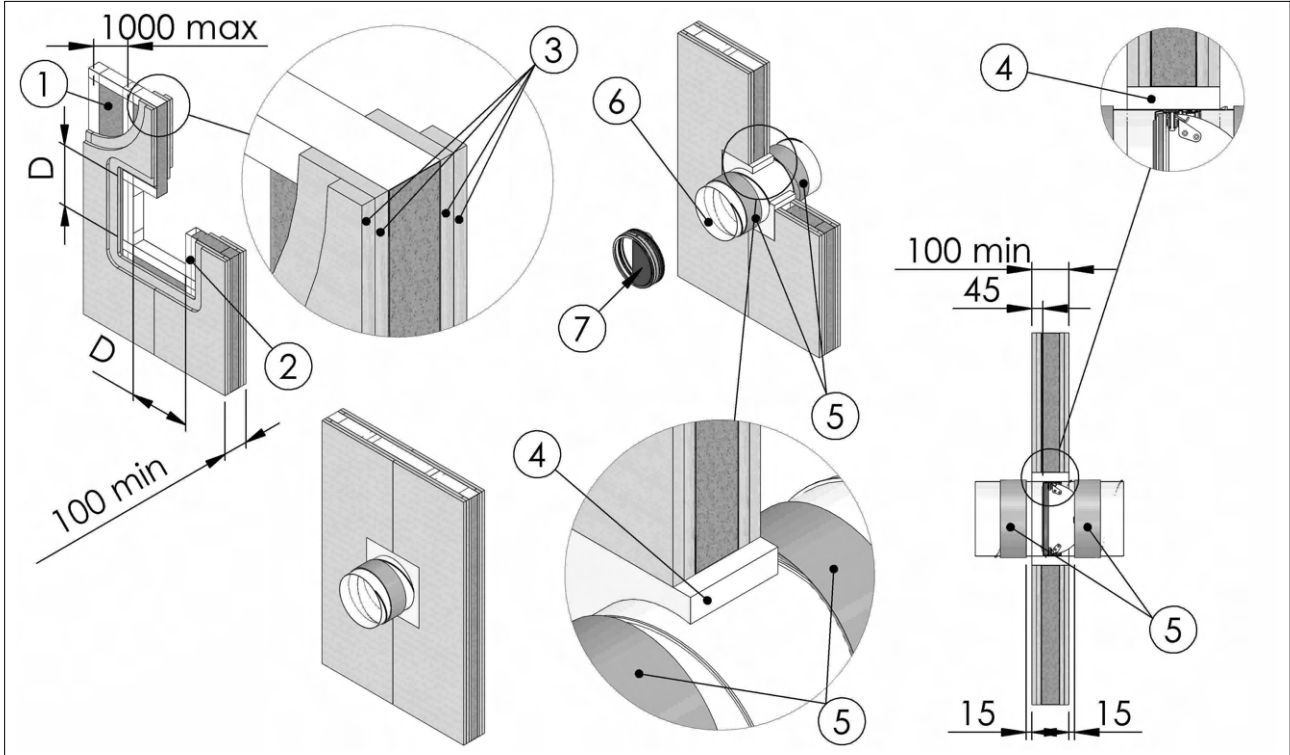

Model FBC4 - FBC7: square hole, mortar or plaster putty covered rock wool sealing

- | | |
|--|---|
| 1. Wall rock wool density according to fire resistance class of the wall | 5. Adhesive gasket (supplied with the damper). Refer to the section Insulation if necessary |
| 2. Metal frame | 6. Ventilation duct |
| 3. Plasterboard, thickness 12,5 mm F type (EN 520) | 7. Fire damper |
| 4. Mortar or plaster putty | 8. Rock wool, 40 kg/m ³ |
| | D from nominal diameter min + 50 to nominal diameter max + 70 |

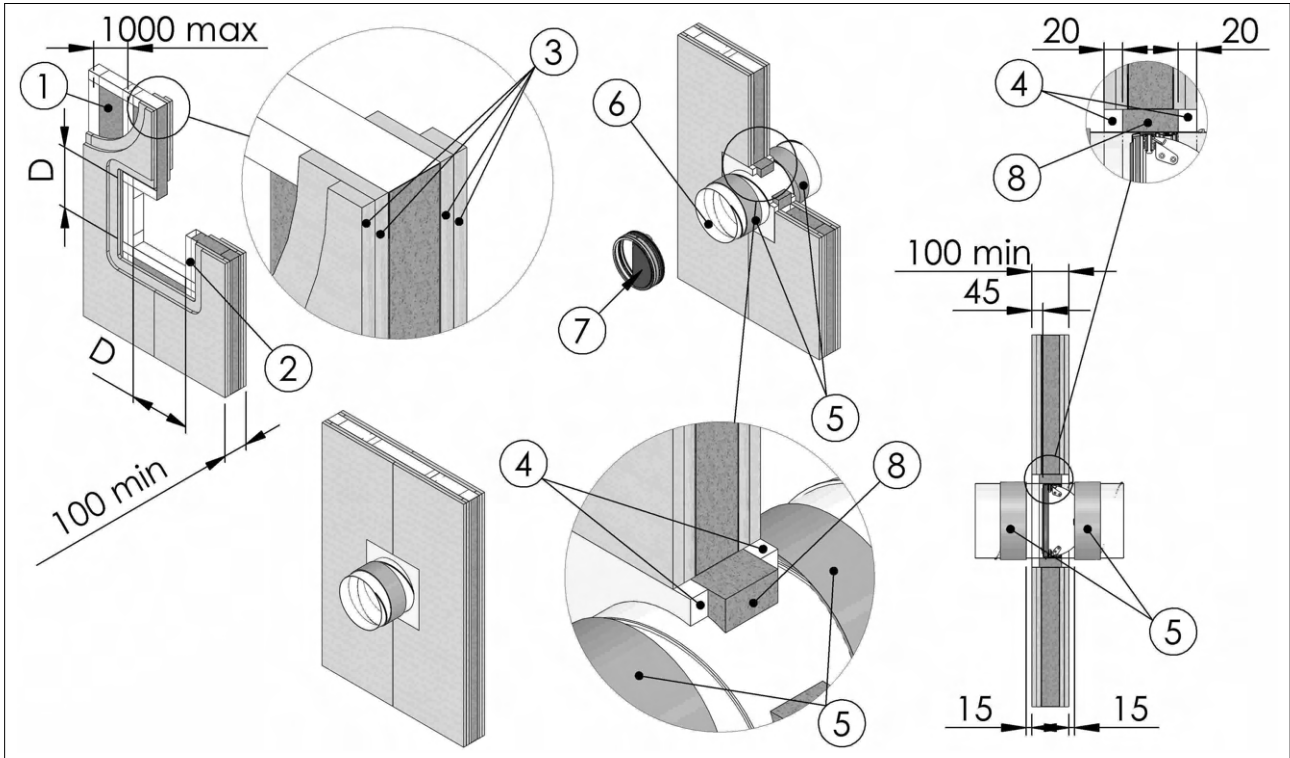

Model FBC4 - FBC7: square hole, plasterboard and rock wool sealing

- | | |
|---|---|
| 1. Wall rock wool density according to fire resistance class of the wall | 6. Self-drilling screw $\varnothing 3,5 \times 45$ mm |
| 2. Metal frame | 7. Fire damper |
| 3. Plasterboard, thickness 12,5 mm F type (EN 520) | 8. Ventilation duct |
| 4. Rock wool, 100 kg/m ³ or mortar or plaster putty | 9. Plasterboard arch infill, thickness 12,5 mm |
| 5. Adhesive gasket (supplied with the damper). Refer to the section Insulation if necessary | D from nominal diameter min + 50 to nominal diameter max + 70 |

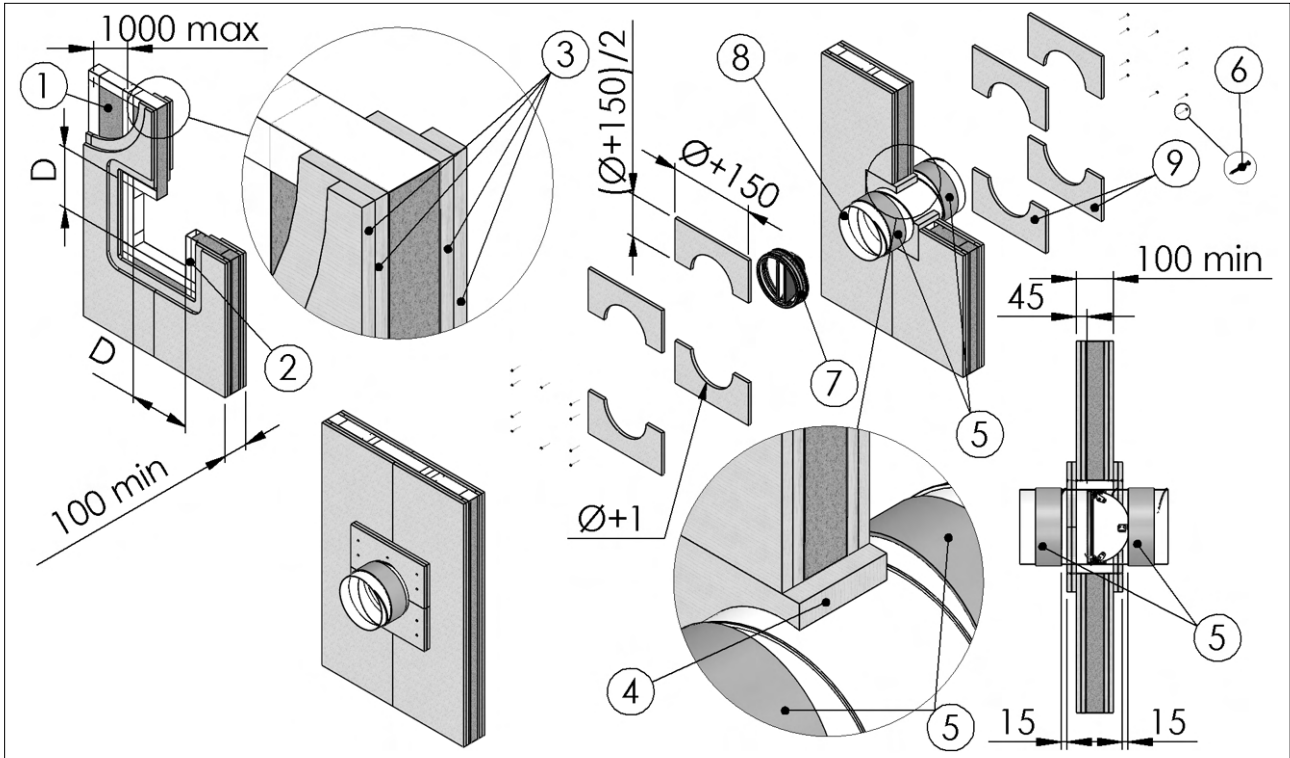

Model FBC4 - FBC7: circular hole, mortar or plaster putty sealing

- | | |
|--|---|
| 1. Wall rock wool density according to fire resistance class of the wall | 5. Adhesive gasket (supplied with the damper). Refer to the section Insulation if necessary |
| 2. Metal frame | 6. Ventilation duct |
| 3. Plasterboard, thickness 12,5 mm F type (EN 520) | 7. Fire damper |
| 4. Mortar or plaster putty | D from nominal diameter min + 50 to nominal diameter max + 70 |

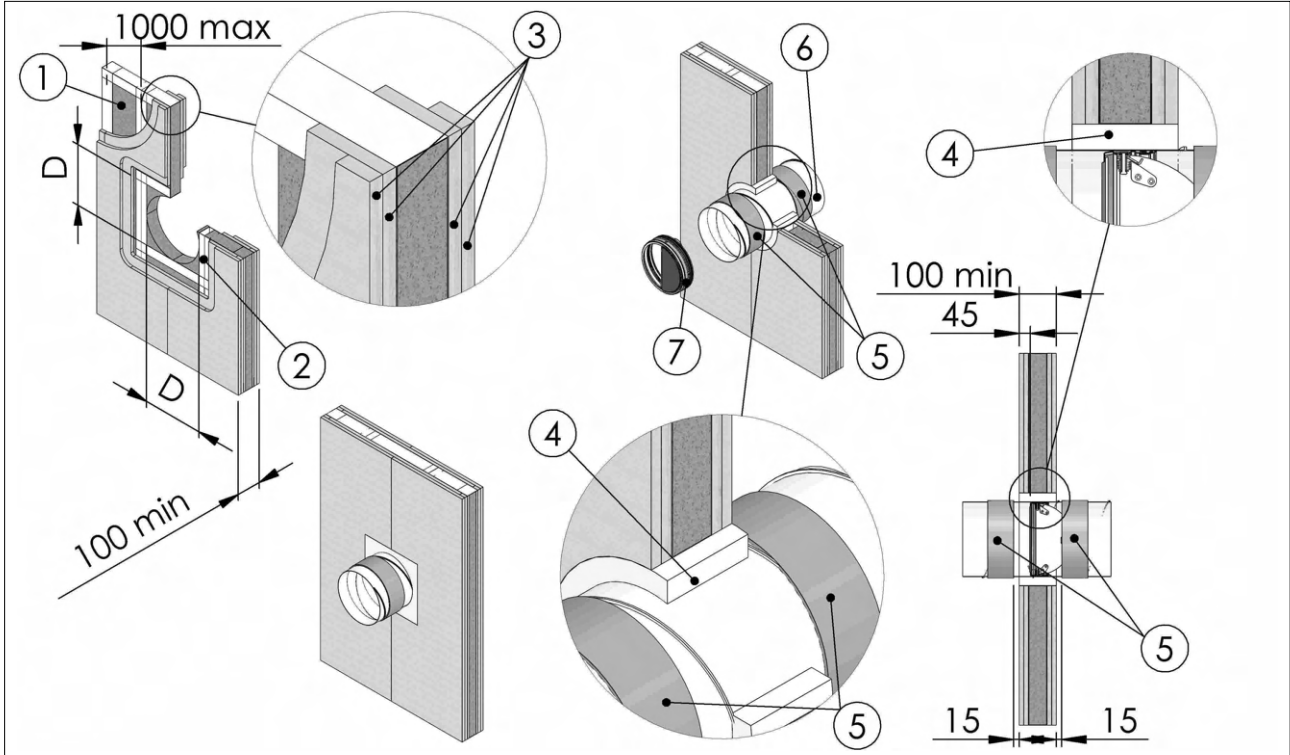

Model FBC4 - FBC7: circular hole, mortar or plaster putty covered rock wool sealing

- | | |
|--|---|
| 1. Wall rock wool density according to fire resistance class of the wall | 5. Adhesive gasket (supplied with the damper). Refer to the section Insulation if necessary |
| 2. Metal frame | 6. Mortar or plaster putty |
| 3. Plasterboard, thickness 12,5 mm F type (EN 520) | 7. Fire damper |
| 4. Rock wool, 40 kg/m ³ | 8. Ventilation duct |
| | D from nominal diameter min + 50 to nominal diameter max + 70 |

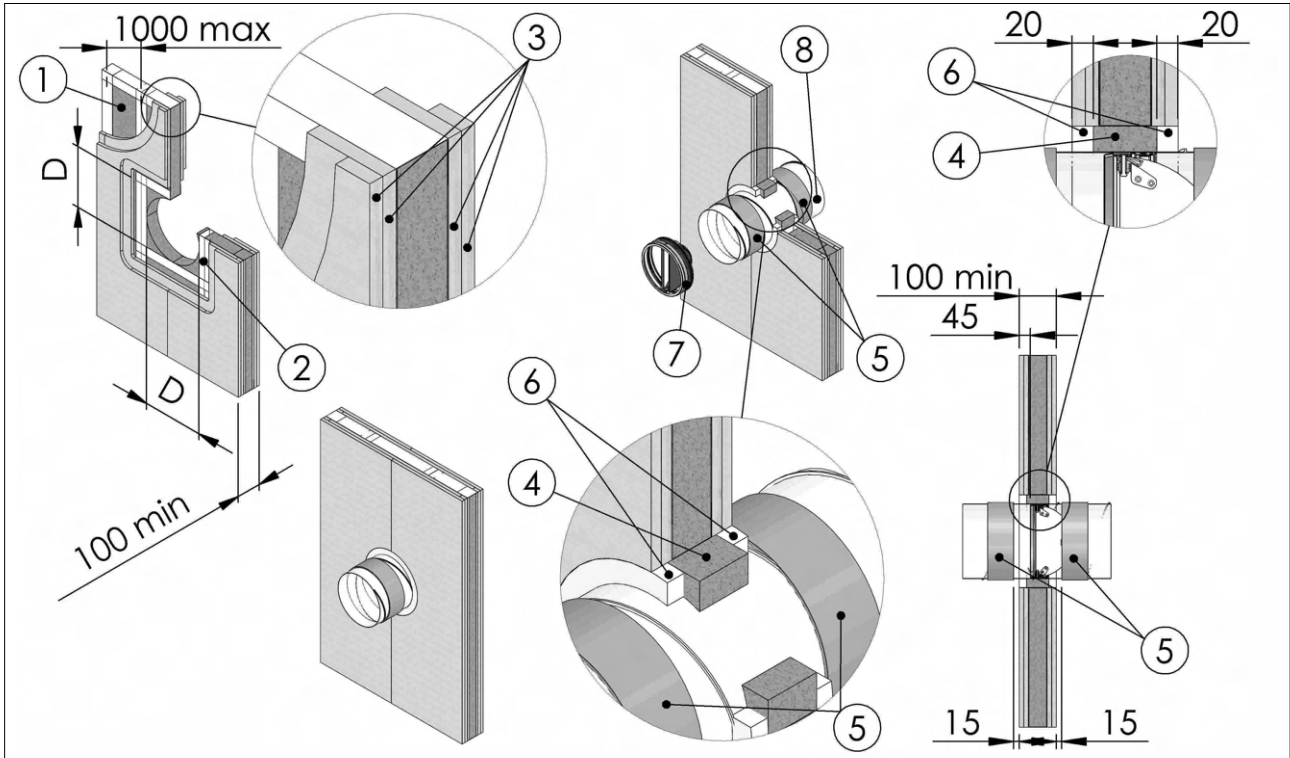

Model FBC4 - FBC7: circular hole, plasterboard and rock wool sealing

- | | |
|---|---|
| 1. Wall rock wool density according to fire resistance class of the wall | 6. Self-drilling screw $\varnothing 3,5 \times 45$ mm |
| 2. Metal frame | 7. Fire damper |
| 3. Plasterboard, thickness 12,5 mm F type (EN 520) | 8. Ventilation duct |
| 4. Rock wool, 100 kg/m ³ or mortar or plaster putty | 9. Plasterboard arch infill, thickness 12,5 mm |
| 5. Adhesive gasket (supplied with the damper). Refer to the section Insulation if necessary | D from nominal diameter min + 50 to nominal diameter max + 70 |

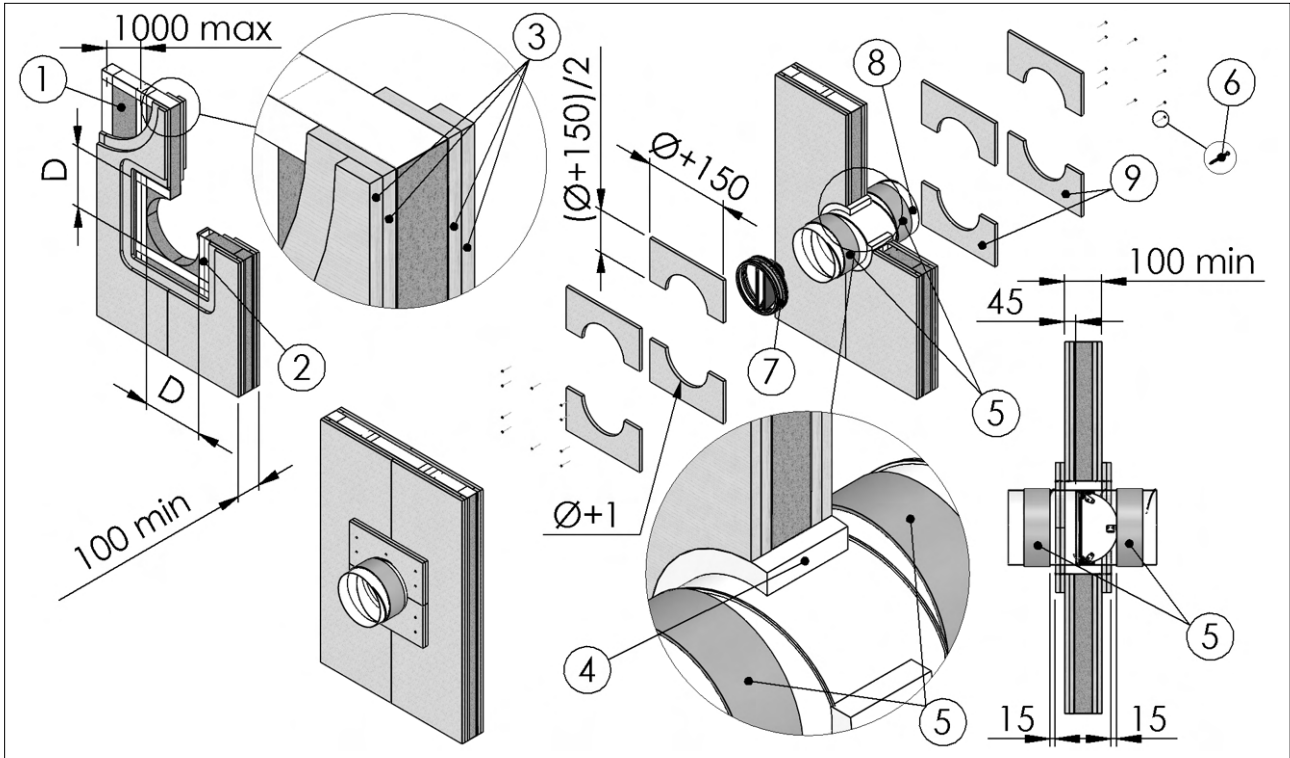

3.9. Installations within floor

Refer to the section Construction supports characteristics [p.13](#) for further information.

Comply with the minimum distances indicated on section Minimum distances [p.12](#).

Before and after installation please perform a functional test. Refer to section Mechanism type for further information [p.8](#).

3.9.1. Floor opening

A opening must be provided in the floor as indicated in the drawing.

3.9.2. Damper positioning

Install the fire damper in the ventilation duct as shown in the drawing.

Close the blade before installing the fire damper.

3.9.3. Filling

Fill the space between ventilation duct and wall as indicated in the drawing. Sealing with concrete is not allowed.

3.9.4. Insulation

Apply the adhesive gaskets supplied with the damper at a distance of 15 mm from the sealing.

Model FBC1 - FBC4 - FBC7: circular hole, mortar or plaster putty sealing

- | | | | |
|----|--|---|--|
| 1. | Adhesive gasket (supplied with the damper). Refer to the section Insulation if necessary | D | From nominal diameter min + 0 to nominal diameter max + 70 |
| 2. | Fire damper | S | = min 100 mm for FBC1, FBC4
= min 150 mm for FBC7 |
| 3. | Mortar | L | = 45 mm for FBC1, FBC4
= 70 mm for FBC7 |
| 4. | Ventilation duct | | |
| 5. | Floor, minimum density 550 kg/m ³ | | |

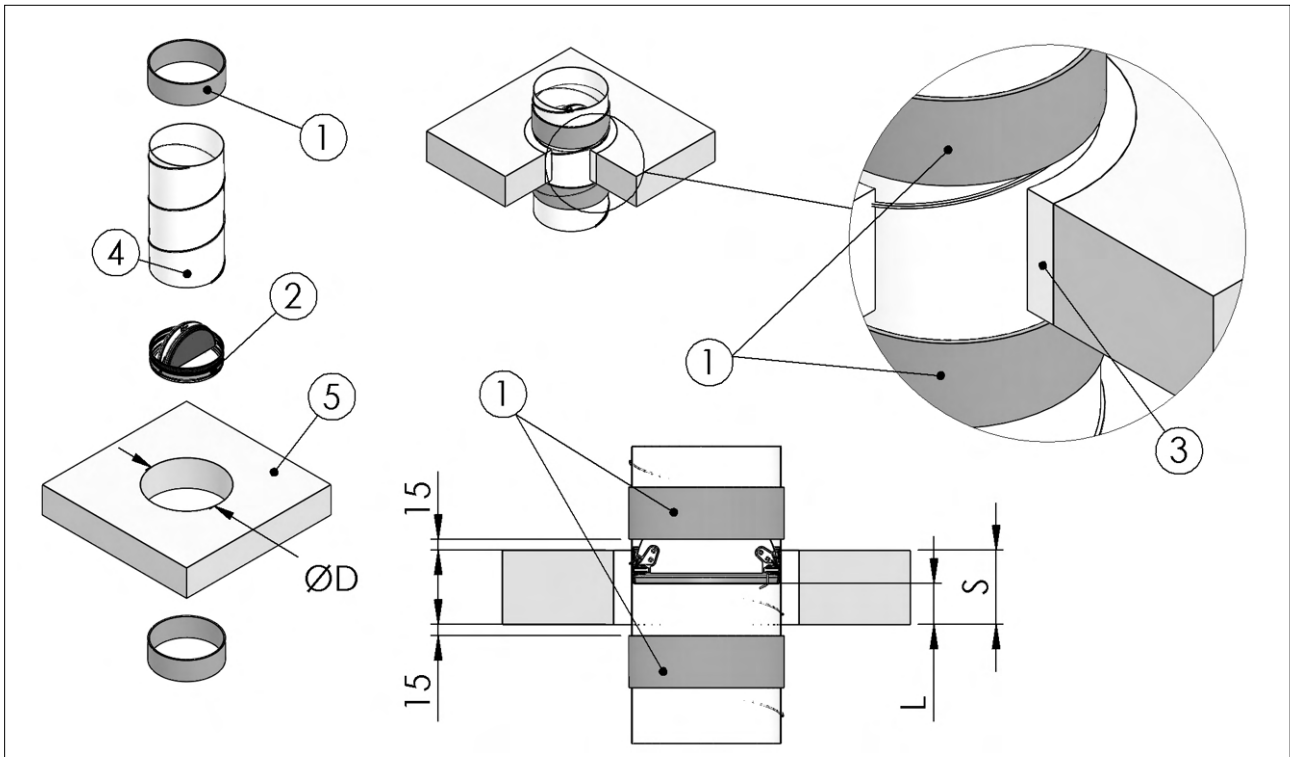

3.10. Installations within vertical wall with Fire Batt (Weichschott) sealing

Refer to the section Construction supports characteristics p.13 for further information.

Comply with the minimum distances indicated on section Minimum distances p.12.

Before and after installation please perform a functional test. Refer to section Mechanism type for further information p.8.

3.10.1. Wall opening

A opening must be provided in the wall as indicated in the drawing.

3.10.2. Damper positioning

Install the fire damper in the ventilation duct as shown in the drawing.

The fire damper has to be fixed at the bottom and suspended from the ceiling.

Close the blade before installing the fire damper.

3.10.3. Filling

Fill the space between the damper and the wall using Fire Batt (Weichschott) sealing made from two rock wool panels with minimum thickness of 50 mm and minimum density of 140 kg/m³.

The panels must be covered on both faces of the wall with endothermic varnish type PROMASTOP E PASTE or HILTI CFS-CT (minimum thickness of 1 mm) and with an internal perimeter sealant type PROMASTOP E PASTE or HILTI CFS-S ACR (minimum thickness of 1 mm).

3.10.4. Insulation

Apply the adhesive gaskets supplied with the damper at a distance of 15 mm from the sealing.

Model FBC1, FBC4, FBC7: square hole, Weichschott sealing

- | | |
|--|---|
| 1. Rock wool panel 50 mm thick with 140 kg/m ³ density. | 6. Adhesive gasket (supplied with the damper). Refer to the section Insulation if necessary |
| 2. PROMASTOP E PASTE or HILTI CFS-S ACR type sealant | 7. Fire damper |
| 3. PROMASTOP E PASTE or HILTI CFS-CT endothermic varnish | D nominal diameter + 600 max |
| 4. Ventilation duct | |
| 5. Wall minimum density ≥550 kg / m ³ or light wall (plasterboard): type A (FBC1) / tiype F (FBC4, FBC7) (EN 520) | |

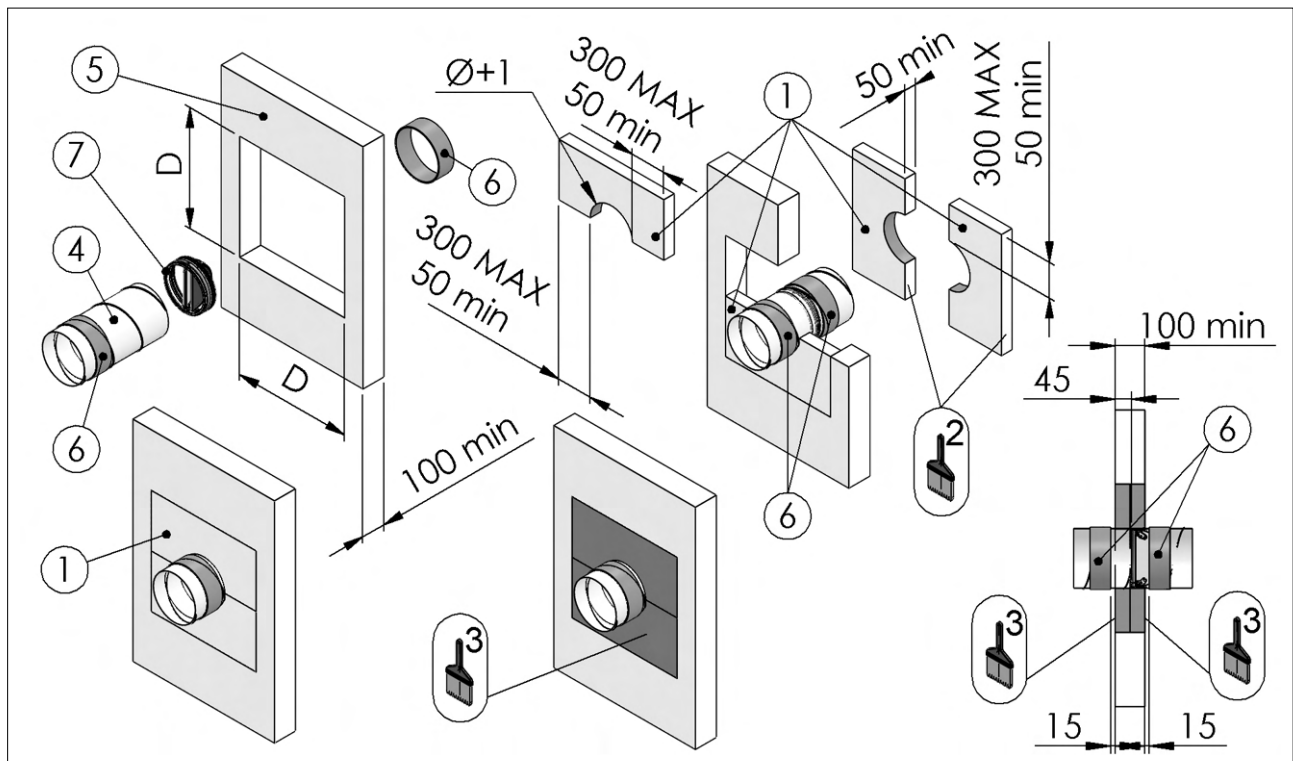

3.11. Installation within floor with Fire Batt (Weichschott) sealing

Refer to the section Construction supports characteristics p.13 for further information.

Comply with the minimum distances indicated on section Minimum distances p.12.

Before and after installation please perform a functional test. Refer to section Mechanism type for further information p.8.

3.11.1. Floor opening

A opening must be provided in the floor as indicated in the drawing.

3.11.2. Damper positioning

Position the damper in the opening so that the side of the closing mechanism extends as indicated in the drawing. The mechanism can be located both above and below the floor.

Close the blade before installing the fire damper.

3.11.3. Filling

Fill the space between the damper and the floor using Fire Batt (Weichschott) sealing made from two rock wool panels with minimum thickness of 50 mm and minimum density of 140 kg/m³.

The panels must be covered on both faces of the wall with endothermic varnish type PROMASTOP E PASTE or HILTI CFS-CT (minimum thickness of 1 mm) and with an internal perimeter sealant type PROMASTOP E PASTE or HILTI CFS-S ACR (minimum thickness of 1 mm).

3.11.4. Insulation

Apply the adhesive gaskets supplied with the damper at a distance of 15 mm from the sealing.

Model FBC1, FBC4, FBC7: square hole, Weichschott sealing

- | | |
|---|---|
| 1. Fire damper | 7. Floor, minimum density 550 kg/m ³ |
| 2. PROMASTOP E PASTE or HILTI CFS-S ACR type sealant | D Nominal diameter + 600 max |
| 3. PROMASTOP E PASTE or HILTI CFS-CT endothermic varnish | S = min 100 mm for FBC1, FBC4 |
| 4. Ventilation duct | = min 150 mm for FBC7 |
| 5. Adhesive gasket (supplied with the damper). Refer to the section Insulation if necessary | L = 45 mm for FBC1, FBC4 |
| 6. Rock wool panel 50 mm thick with 140 kg/m ³ density. | = 70 mm for FBC7 |

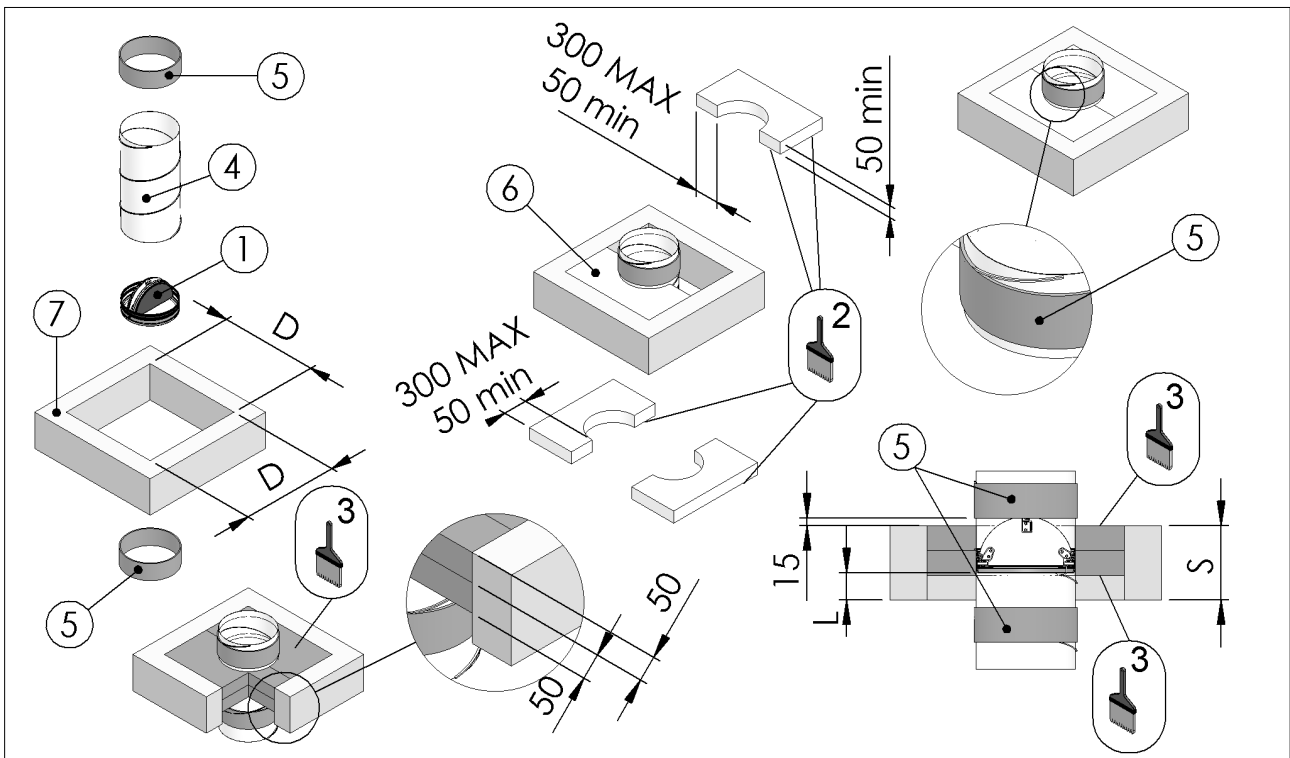

4. ELECTRICAL CONNECTIONS

4.1. Electrical wiring

Electrical connections must be done by qualified and trained people.

Switch off the power supply before starting any work on the electric elements. Never switch on the power supply during electrical connections.

4.1.1. Wiring diagram for position microswitches

FCU: Closed damper contact

- A The fire damper's blade is open (the air flow is allowed)
- B The fire damper's blade is closed (the air flow is not allowed)
- 4 Normally opened (BLUE)
- 1 Common/neutral (BLACK)
- 2 Normally closed (GREY)

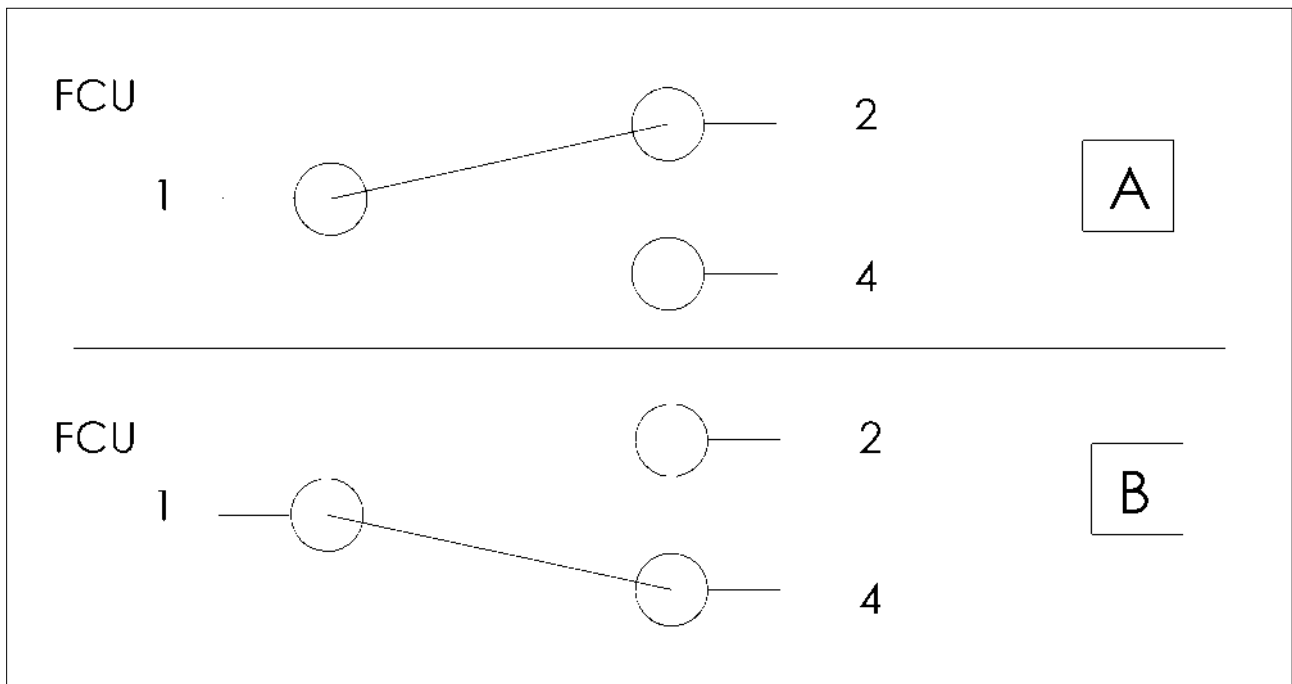

1mA 4V AC min
6A 250V AC max

5. MAINTENANCE AND INSPECTIONS

Fire dampers and control mechanisms do not require routine maintenance.

Extraordinary maintenance (repairs) and periodic inspection operations are the responsibility of the ventilation system operator.

It is recommended to provide inspection hatches on both sides of the ducts connected to the fire damper.

The implementation of a periodic inspection plan allows to guarantee the efficiency and functionality of the fire dampers for the fire safety of the building.

5.1. Periodic inspection and cleaning

Periodic inspection shall be performed in accordance with the requirements of the law or by the building regulations or other local regulations.

In the absence of specific regulations (or to their complement), in accordance with point 8.3 of the EN 1560 standard, it is recommended to carry out the following control activities at intervals of no more than 12 months:

- Check the servomotor electrical wiring for damage (where applicable);
- Check end-switch wiring for damage (where applicable);
- Check damper cleanliness and clean where necessary;
- Check the condition of blades and seals, rectify and report where necessary;
- Check the correct opening and closing of the fire damper by manual operation according to the instructions in the technical manual of the fire damper;
- Check the opening and closing operation of the damper controlled by the fire alarm system (if present);
- Check the operation of the end switches in open and closed state, adjust and report if necessary;
- Confirm that the damper fulfils its function as part of the control system (where necessary);
- Check that the damper is left in its normal operating position, which usually corresponds to the open position.

5.2. Repair

For safety reasons, repair activities involving fire-fighting components must be carried out only by qualified personnel.

Only original spare parts supplied by the fire damper manufacturer must be used.

A functional test must be performed after each repair.

At the end of the inspection, cleaning or repair operations, check that the fire damper is in the normal operating position.

Keep records of all inspections, repair activities, any problems encountered and their resolution.

This practice, even when not mandatory, is very useful in practice.

5.3. Disposal

Disposal in case of destruction must be carried out in accordance with national legislation. For electrical and electronic parts also refer to EU Directive 2011/65.

6. SELECTION

6.1. Air flow rates in relation to the diameter

\emptyset mm	Front section m ²	Net section m ²	Maximum air flow m ³ /h	Maximum speed m/s
100	0,008	0,002	179	6
125	0,012	0,004	346	8
160	0,020	0,010	652	9
200	0,031	0,017	1216	11

6.2. Air flow rates as a function of the pressure drop

\emptyset mm	ΔP 20 Pa		ΔP 30 Pa		ΔP 40 Pa	
	Q m ³ /h	Lw dB(A)	Q m ³ /h	Lw dB(A)	Q m ³ /h	Lw dB(A)
100	78	34,6	96	39,7	112	43,5
125	160	37,6	196	42,2	226	45,4
160	357	39,5	437	44,7	504	48,4
200	756	43,7	922	48,4	1061	51,8

6.3. Air flow rates as a function of generated sound levels

\emptyset mm	Lw 30 dB(A)		Lw 35 dB(A)		Lw 40 dB(A)	
	Q m ³ /h	ΔP Pa	Q m ³ /h	ΔP Pa	Q m ³ /h	ΔP Pa
100	65	14,1	79	20,5	97	30,3
125	114	10,2	143	16,0	178	24,9
160	246	9,4	299	14,0	364	20,8
200	423	6,1	523	9,4	645	14,5

6.4. Pressure drop and sound level graph

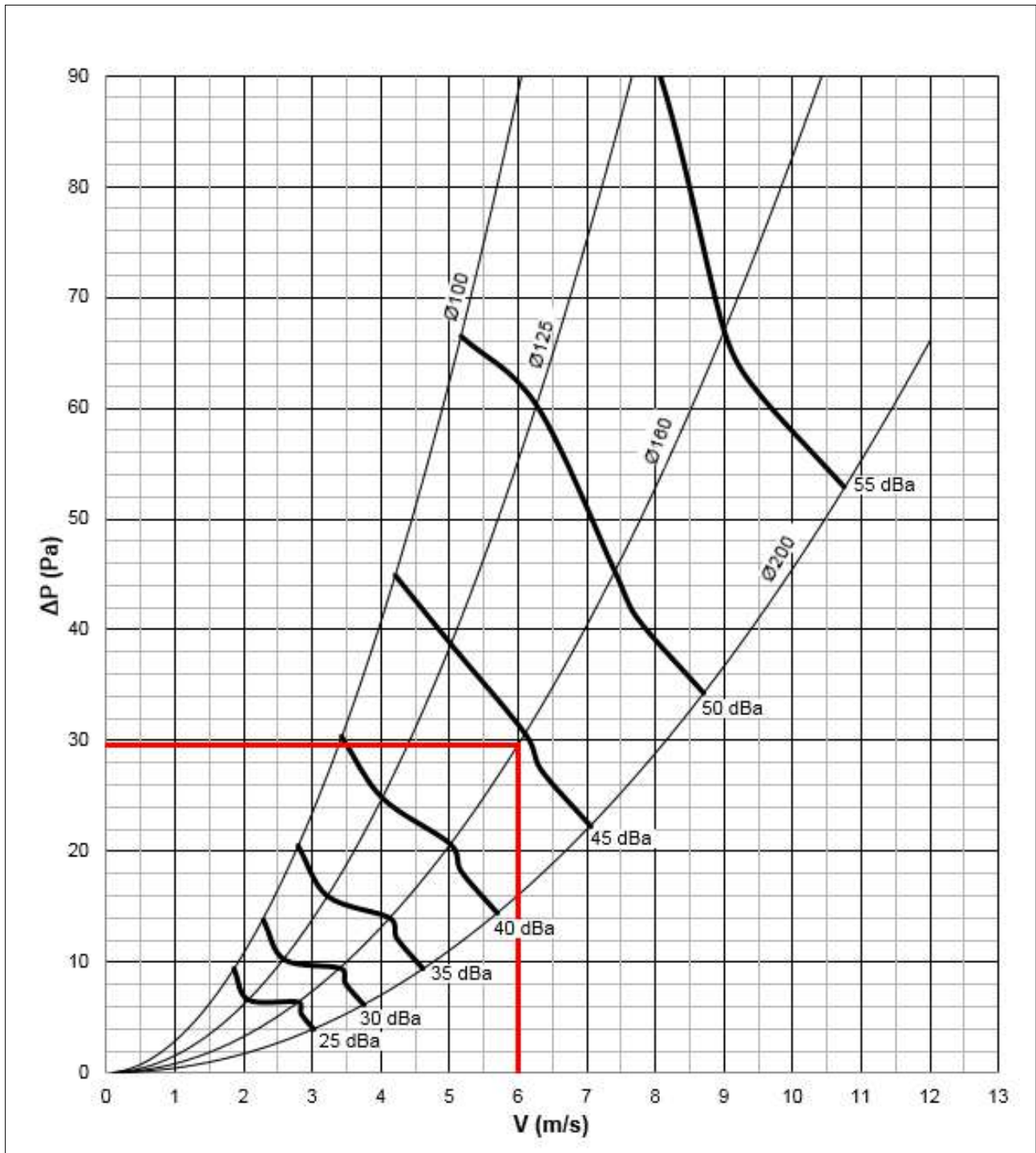

Ø	Lw 30 dB(A)		Lw 35 dB(A)		Lw 40 dB(A)	
	Q	ΔP	Q	ΔP	Q	ΔP
mm	m ³ /h	Pa	m ³ /h	Pa	m ³ /h	Pa
100	65	14,1	79	20,5	97	30,3
125	114	10,2	143	16,0	178	24,9
160	246	9,4	299	14,0	364	20,8
200	423	6,1	523	9,4	645	14,5

6.5. Sound spectrum table

Correction used to estimate the octave band spectrum (Values to be added to the noise levels in dB(A))

Ø100

Hz	Speed (m/s)					
	2	4	6	8	10	12
63	9,3	3,9	-0,8	-4,8	-8,1	-10,7
125	3,3	-4	-9,7	-13,7	-16	-16,8
250	0	-2,5	-5,1	-7,8	-10,5	-13,3
500	-3,6	-3,4	-3,6	-4,1	-4,9	-6,1
1000	-7,3	-6,7	-6,3	-6,1	-6	-6
2000	-12,4	-8,7	-6,3	-5,4	-5,8	-7,6
4000	-9,9	-9,5	-9	-8,4	-7,7	-7
8000	-7,1	-11,1	-13	-12,9	-10,8	-6,7

Ø125

Hz	Speed (m/s)					
	2	4	6	8	10	12
63	6,2	3,5	0,7	-2,2	-5,1	-8
125	1	-1,6	-4	-6,4	-8,6	-10,7
250	-1,6	-1,8	-2,5	-3,6	-5,1	-7,1
500	-6,9	-5,2	-4,4	-4,6	-5,6	-7,6
1000	-8,3	-7,3	-6,7	-6,6	-7	-7,8
2000	-11,4	-8,1	-6,1	-5,3	-5,8	-7,5
4000	-8,9	-9	-8,8	-8,2	-7,3	-6,1
8000	-5,3	-10,5	-13	-13	-10,3	-5,1

Ø160

Hz	Speed (m/s)					
	2	4	6	8	10	12
63	14,1	5,3	-1,3	-5,6	-7,7	-7,6
125	6,2	1,3	-2,5	-5,3	-7,1	-7,8
250	1	-1	-2,6	-4	-5,1	-5,9
500	-4,8	-4,5	-4,5	-4,8	-5,5	-6,4
1000	-7,9	-7,6	-7,5	-7,5	-7,8	-8,2
2000	-10,8	-8,1	-6,4	-5,6	-5,7	-6,8
4000	-11	-9,4	-8,2	-7,3	-6,7	-6,5
8000	-2,4	-8,8	-12,5	-13,3	-11,3	-6,6

Ø200

Hz	Speed (m/s)					
	2	4	6	8	10	12
63	12,4	6,7	2	-1,6	-4,1	-5,5
125	15,1	8,1	2,7	-0,9	-2,9	-3,2
250	-3,5	-2,4	-2	-2,3	-3,3	-5
500	-9,5	-6,7	-5	-4,6	-5,4	-7,3
1000	-11,9	-8,6	-6,6	-5,8	-6,2	-7,8
2000	-14,5	-10,4	-7,5	-5,9	-5,6	-6,6
4000	-9,3	-9,4	-9,2	-8,6	-7,7	-6,4
8000	1,1	-7,2	-12,4	-14,5	-13,5	-9,4

7. ACCESSORIES AND SPARE PARTS

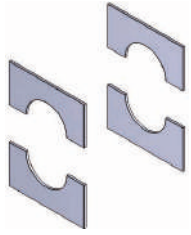

Arch infill panels for plasterboard installation from Ø 100 to Ø 200 (thickness 12.5 mm)

TAMP-WH25-Ø

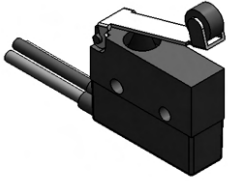

Closed damper microswitch

FBCFC

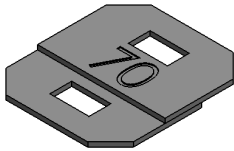

Thermofuse with 70 °C setting for FBC

FBC70

8. HOW TO ORDER

Code	
Product type	FBC Circular fire damper butterfly type
	1 Classification EI 60 S without terminal valve
Model	4 Classification EI 90 S without terminal valve
	7 Classification EI 120 S without terminal valve
Position indication microswitches	S0 Without position microswitch
	S1 With position indication microswitch
Dimension	XYZ Nominal diameter (mm)
Examples	Code
Fire damper EI 120 S without valve and without microswitch Ø 200	FBC7-S0-200
Fire damper EI 60 S without valve and without microswitch Ø 100	FBC1-S0-100
Fire damper EI 90 S without valve and with microswitch Ø 125	FBC4-S1-125

9. SPECIFICATION TEXT

9.1. Circular fire damper series FBC Butterfly

Description

FBC1, FBC4, FBC7 circular fire damper tested for fire resistance and smoke seal with 300 Pa depression as per EN 1366-2, classified according to EN 13501-3 and CE marked according to European Regulation UE 305/2011 and EN 15650 standard.

Allows maximum safety for fire protection inside buildings providing perfect heat insulation and smoke tightness.

Technical characteristics

- Available diameters from 100 to 200 mm
- Case made from galvanized sheet steel, with a total length of 50 mm equipped with duct connection gaskets.
- Closing mechanism with thermal release and manual reset
- Blade damper made from calcium silicate insulating material, rotating on steel gudgeon pins, complete with polyethylene gasket for the air seal of cold smoke, as per EN 1366-2
- Thermal, expanding graphite gasket
- Thermal fuse with melting point certified ISO 10294-4 at 70 °C
- Absence of thermal bridge between the faces of the installation wall

Installation

- Installation within vertical rigid walls made from aerated concrete blocks, standard concrete or masonry with a minimum thickness of 100 mm and minimum density of 500 kg/m³
- Installation within light plasterboard walls with minimum thickness of 100 mm
- Installation within concrete floors or aerated concrete with minimum thickness 100 mm (FBC1, FBC4,) or 150 mm (FBC7) and minimum density 550 kg/m³
- Installation with Fire Batt (Weichschott) sealing within vertical rigid walls made from aerated concrete blocks, standard concrete or masonry with minimum thickness 100 mm and minimum density 550 kg/m³
- Fire Batt (Weichschott) sealing installation within vertical light wall (plasterboard) with minimum thickness 100 mm
- Installation with Fire Batt (Weichschott) sealing within concrete floors or aerated concrete with minimum thickness 100 mm (FBC1, FBC4,) o 150 mm (FBC7) and minimum density 550 kg/m³
- Fire resistance characteristics independent from direction of the source of the fire according to EN 1366-2 article 6.2
- The fire damper can be installed with the blade axis positioned vertically or horizontally or tilted at any angle.

Accessories

- Microswitch with three NO/NC position detecting connectors for open and closed damper

10. REVISION INDEX

Revision n°	Date of issue	Description
19/11	2019/11	First issue
20/02	2020/02	Ø180 remove
20/10	2020/10	Updated section: <ul style="list-style-type: none">• Installation p.11• Not allowed uses p.11• Periodic inspection and cleaning p.40 Updated table: <ul style="list-style-type: none">• Fire resistance classification according to EN 13501-3-2009 p.5 General improvements